

Company Profile

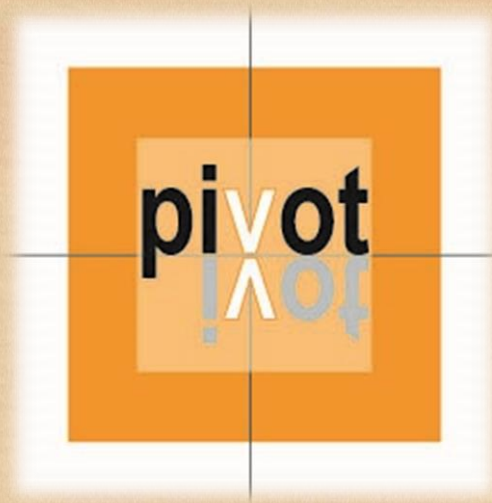

PIVOT ENGINEERING LTD.

Energy, Water, Heat, Fabrication & Erection Experts

BD Office: 389/B, MG Tower, DIT Road, Level-8, West Rampura, Dhaka-1219, Bangladesh.
Phone: +88-02-9343024, Cell: 01914-012318, 01715-297538 Fax: +88-02-9338076.

INTRODUCTION

Pivot Engineering Limited (PEL) organized by a group of professional engineers, initiated at 2007 but incorporated in April 2009 under the company act of XVIII 1994 and started immediate functioning in the field of extensive engineering consultancy for the sector of Energy, Water, Heat, Fabrication, Erection & Installation. Since then it has never looked back and has grown and diversified into a multi-tasked civil, mechanical, electrical & industrial engineering organization.

PEL has become a full-fledged Engineering Company comprised of graduate engineers of various disciplines mostly from BUET/CUET/RUET and also very experienced diploma engineers and technicians. All of the Engineers and technicians have enriched their technical skill by the professional training & experience in the related fields in addition to their brilliant academic background. Our principal business activities extended already into energy saving projects in power plant sector and environment friendly projects. To fulfill the Moto of Green Bangladesh, we have successfully executed some EPC and turn-key project on waste heat recovery.

PEL is well equipped & facilitated with engineering workshop at suburb of Dhaka. It can handle the fabrication work of mild steel (MS), cast iron, galvanized iron (GI), copper, PVC and even critical jobs of different graded low carbon stainless steel (SS).

PEL is fully equipped with manpower, software's and tools to execute efficient design & drawing of various projects and undertake erection works as well by latest fabrication facilities, dedicated customer service team having superb capability.

PEL is committed to grow in Bangladesh with more stringent quality controls and better customer service and to establish itself as an exclusive brand through its quality management system conforms to ISO9000.

Company Vision

- To Conglomerate as a complete engineering solution provider focusing on green technology for cleaner environment maintaining optimum quality level and price.

Company Mission

- To be the market leader in Bangladesh, in the field of Cogeneration, WTP, ETP and Energy/heat recovery projects by 2021.
- To forecast on green technology in Bangladesh by 2021.
- To train up 15 employees every year as a part of human resource management development.
- To build an image for quality EPC/turnkey contactor by 2021.
- To achieve 10% sales growth every year.
- To establish customer service department (CSD) by 2021 in order to achieve maximum customer satisfaction.

Resources

Name: Pivot Engineering Limited

Established: March 2007, Incorporated at: 8th April, 2009

Capital: Tk.150, 000,000/- (In word- Taka One Hundred and Fifty Million only)

Corporate Office

389/B, MG Tower, Level-8, West Rampura, Dhaka-1219, Bangladesh.

Phone: +88-02-9343024, Fax: +88-02-9338076

E-mail: info@pivotengg.com, pivotengg@gmail.com

URL: www.pivotengg.com

Factory & Workshop:

Zinjira, (Near Kalma Bazar & Dairy Farm), Birulia, Savar, Dhaka, Bangladesh.



PEL Strength

- Group of experienced & professional engineers & technicians
- Dynamic & innovative work force
- Indomitable commitment for customer satisfaction
- Quality Management Systems
- Farsighted business vision
- Ability to handle turn-key projects and BOP of projects
- EPC (Engineering, Procurement and Construction) contracting of the projects
- Total water and energy management consultancy
- Retrofitting jobs
- Strong R&D with latest lab facilities
- Well-equipped after sales service team also for undertaking annual service contracts.

General Information

NAME : **PIVOT ENGINEERING LTD.**

Year of Establishment : **Established: March 2007, Incorporated at: 8th April, 2009.**

Certificate of Incorporation No. : **C76013/09**

Type of Organization : **Private Limited Company**

Address:

Head Office/Business : **389/B, MG Tower, Level-8, West Rampura, Dhaka-1219, Bangladesh.**

Telephone : **+88-02-9343024**

Fax : **+88-02-9338076**

E-mail : **info@pivotengg.com**

URL : **www.pivotengg.com**

Certificates : **ISO 9000-2008, ISO 14000, IEE/EIA reporting**

Trade License No. : **03-087481**

Electronic Tax Identification No. (e-TIN) : **1173-1739-9268**

BIN No. : **001009326-0208**

International Business Associates with PEL

- ❑ **Greens Power Ltd., UK:** The mother company is Greens, UK established in the year 1833. Inventor of economizer at 1845, EGB & HRSG maker and an expert EPC player for thermal and power engineering project.
- ❑ **GP Green Energy Systems PVT. Ltd, Pune/Kolkata, India:** A professional company on waste to energy, heat recovery system, energy saving projects.
- ❑ **Soon Ngai Engineering Sdn. Bhd, Malaysia:** Providing highly functional equipment, media and engineering system for water & waste water treatment plant.
- ❑ **Tremendous Industries SdnBhd, Malaysia:** A water management company provides complete solutions for domestic, commercial and industrial water treatment system.
- ❑ **ROSS Boiler, India:** A manufacturer of Thermic Fluid Heater (Thermal Oil Boiler), Hot Water Boiler/Generator and solid fuel boiler (Husk, Coal, wood, agro-waste, saw dust)
- ❑ **TrunDean Machinery Co. Ltd., Taiwan:** A professional manufacturer of industrial roots blower for effluent treatment plant.
- ❑ **Nanfang Pump Industry Co. Ltd., China:** Manufacturer of wide ranges of pumps for all applications (Domestic, Commercial & Industrial)
- ❑ **Aktes Boiler, Turkey:** Manufacturer of oil & gas fired packaged steam boiler.
- ❑ **Lenntech, Netherland:** Exclusive water treatment technology like DM plant, EDI etc.
- ❑ **Macroprocess, China:** Purified water (PW), Water for Injection (WFI), Pure Steam (PS), clean room & HVAC for pharmaceuticals applications.
- ❑ **PUMA, Turkey:** Air Compressor of all applications.
- ❑ **Chiwatec, China:** Water treatment, waste water treatment, sewerage water treatment specially designed for GREEN projects (Platinum/Gold category LEED commercial or industrial projects).
- ❑ **SKODA/NTC, China:** Steam Turbine of all applications.

- ❑ [Qingdao Xinguangzheng Steel Structure co. LTD, China](#): Founded in 1996,has been specialize in designing and manufacturing steel structure buildings, steel structure workshop, steel structure warehouse, aircraft hangar, prefab house and container house.
- ❑ [Iking, China](#): IKING GROUP established in 1995, a leading manufacturer and exporter of Glass Wool Blanket, Glass Wool Board, Rock Wool Board, Rock Wool Blanket, Rubber Foam Pipe, Rubber Foam Insulation & Insulation related accessories in China.
- ❑ [Shanghai Guangdian Electric Group Co. Ltd., China](#): Established in 1986, rank the top PTD industry in Shanghai. Main products are Indoor A.C. Metal-Clad Enclosed Switchgear, Gas insulation switchgear, Laser welding, Automatic helium leak detection device, LV Extraction type switchgear, Circuit Breaker, M-PRO Trip Unit, AC/DC Cubicle, Paralleling Inverter, Cast Resin Dry-Type Power Transformer, etc.
- ❑ [Hebei Shengtian Pipe Fittings Group Co. Ltd , China](#): Established in 1989.Main products are Carbon steel Pipes, Stainless steel pipes, Elbow, Tees, Bends, Reducers, Caps, Flanges and Sockets etc.
- ❑ [Shenzhen Minle Pipe Industry Co. Ltd, China](#): This company is specialized in various thin-wall stainless steel products like stainless steel water supply pipe, pipe fitting, stainless steel drainage-pipe, plastic covered stainless steel pipe and valve components etc.
- ❑ [Kinglai Hygienic Materials Co. Ltd, China](#): Kinglai is a world renowned complete source for specialized fittings and tubing required in food, dairy, beverage, biotechnology and pharmaceutical application.
- ❑ [Leo Swan Industrial Pump Co. Ltd, China](#): Leo Swan is the first listed company in China's pump industry. one of the pinpoint manufacturers that are appointed by National Power Consultation Co., Ltd. for large capacity pumps.
- ❑ [Spirax Sarco, India](#): Founded in 1888, Largest manufacturer of all kinds of Steam accessories. It provides engineered solutions for the design, maintenance and provision of efficient industrial and commercial steam systems.



Local Business Associates with PEL

1. Nipobon Real Estate Limited:

- Development of apartment buildings, commercial building etc.
- Construction of industrial projects specially for ETP and WTP tanks and machine foundations.
- Steel Pre-fabricated building works.
- Plumbing, sanitation, drainage, boundary walls etc.

2. Transtech Technologies Limited:

- Designing of electrical works for residential, commercial and industrial projects.
- Designing, Supply, installation and commissioning of building wiring, earthing, lighting etc. system
- Designing, supply, installation of various kinds of electrical panels, breakers, MDB/SDB, BBT, cable tray etc.
- Cable and cable tray laying, termination etc.



Call PEL For

- Projects, Co-generation, tri-generation, secondary generation and combined
- Project planning and Turn-key Erection & installation jobs
- Industrial project layout planning.
- Energy auditing and thermal engineering solutions.
- Energy recovery system/ energy conservation system.
- Industrial erection and fabrication jobs especially in any kind of power plant.
- Designing of utility (Hot Water/cold water/Air/oil/steam/gas/power etc.) network system for industries.
- Water treatment system (WTS).
- Effluent treatment plant (ETP) and Sewerage Treatment Plant (STP).
- Project Commissioning, Repairing and After Sales Service of Steam boiler/Thermo-oil boiler/ Hot water Generator.
- Fabrication of Engineering items like pressure vessels, water/air/oil/chemical tanks, chimney, heat exchangers.
- Consultancy on ISO 9000-2008, ISO 14000, IEE/EIA reporting.
- EPC of Auto Bricks plant, Cottage & CNG filling station.

Specific experience profile of Biomass/Waste Heat Recovery Steam/Power Generation Plant:

- Supply, installation and commissioning of various kinds of valves and instruments at Jhulda **100 MW HFO Power Plant**, Chittagong. (Acron-BanglaCAT).
- **Detail engineering and mechanical erections works** of RPCL 50 MW HFO Power Plant, Kodda, Gazipur. (CPCL-RPCL).
- **Cable Termination work and commissioning** at 200MW Bangla Trac Power Plant, Daudkandi, Comilla.
- **Scopes at RPCL 54MW HFO Power Plant:**
 1. Detailing of Basic layout and P&I diagram provided by Wartsila for their 6 nos HFO engines (Model: 20V32GD) and auxiliaries.
 2. Leveling and alignment of engines and auxiliaries.
 3. Laying, supporting, fabrication, fitting, fixing, erection and testing (DPT & hydro) of piping system for
 - HFO fuel system
 - LFO fuel system
 - Lube oil system
 - Compressed air system
 - Steam & condensate system
 - Raw water, DM Water & oily water system
 - Exhaust stack, duct with supports and structures
 - Radiator & charge air platform
 - Ladder and walkway inside and outside engine hall.
- Turn-key contracting of **10 MW Bio-Mass Co-generation Project** of Pabna Power Ltd (AR Group-Pabna). This will be the biggest automatic rice mills project with self-power generation facility through its by product (rice husk) under construction.
- EPC contracting of **3.3 MW Secondary Power Plant** based on waste heat sources of a **50 MW HFO Baraka Power** at Patenga, Chittagong with association of Greens Power Ltd, UK.

Scopes:

- Exhaust Gas Boilers & HT water heat exchangers.
 - EGB structures.
 - Steam Turbine set with condensing and cooling unit.
 - Water Treatment Plant (Pre-treatment, DM & RO).
 - Auxiliary/start-up Boiler Plant.
 - Internal piping, automation & communication system.
- Turn-key contracting of **Waste Heat Recovery Hot Water System** at Square Hospitals Ltd., Panthapath, Dhaka.

Scopes:

- Waste Heat Recovery Hot Water Boiler on CAT G3512 engine.
 - Calorifiers
 - Electric boilers
 - Hot water circulation pumps
 - Hot water distribution piping (Copper pipes of different sizes)
- Designing, supply, installation and commissioning of **Balance of the Plant (BOP) of 16 MW cogeneration plant** at United Ashuganj Energy Ltd 200MW Modular CCPP.

Scopes of works at UAEL-200MW/16 MW Cogen:

- Installation of Boilers
 - Installation of Steam Turbine Package
 - Supply, installation & commissioning of DM Water plant.
 - Supply, installation and commissioning of Condenser cooling water system which includes 7x1000 m³/hr pumps, 1200 mm dia FRP piping etc.
- Supply, installation and commissioning of **6 TPH Husk Boiler of JN Industries**, Dupchachia, Bogra. The unit was complete with Economizer, Air Pre-heater and Mechanical Dust Collector (MDC).
- Supply of **Economizers** for Steam Boilers (4 sets) at **Envoy Textiles**
- Supply of **Waste Heat Recovery Boiler** (1 set) at Chaity Composite Textiles Ltd.

- Designing, supply, installation and commissioning of **Balance of the Plant (BOP) of 2x6.6 MW cogeneration plant** at United Mymensingh Power Ltd (200MW HFO Power plant with co-generation).

Scopes of works at UMPL-200MW/2x6.6 MW Cogen:

- Installation of Cooling Towers- 4 cells.
- Cable & cable tray laying & termination of boiler, STG & cooling system.
- Supply, installation & commissioning of DM Water plant.
- Supply, installation and commissioning of Condenser cooling water system which includes 5x1275 m³/hr pumps, 900 mm dia cooling piping etc.

Installation and commissioning of **Balance of the Plant (BOP) of 1x6.6 MW Cogeneration plant** at Orion Rupsha Power Ltd (115MW HFO Power plant with cogeneration).

Scopes of works at Orion Rupsha Power Plant-115MW/6.6 MW Cogen:

- Installation of Boilers
- Installation of Steam Turbine Package
- Supply, installation & commissioning of DM Water plant.
- Installation of cooling tower.

- EPC contracting of **2x3.15 MW Secondary Power Plant** based on waste heat sources of a 113 **MW HFO Confidence Power** Rangpur Ltd at Pairabond, Rangpur with association of **Greens Power Ltd, UK.**

Scopes:

- 16 sets Exhaust Gas Boilers & HT water heat exchangers.
- 1 lot EGB structures, ladder & platform
- BOP of 2 sets Steam Turbine set with condensing and cooling unit.
- Water Treatment Plant (Pre-treatment, DM & RO).
- Auxiliary/start-up Boiler Plant.
- Internal piping, automation & communication system, SCADA etc.

EPC EXPERIENCE ON NON-POWER PROJECT:

- **RAJSHAHI AUTO BRICKS LIMITED:** PALOPARA, NOWHATA, RAJSHAHI

PRODUCTS: CLAY BRICKS

TECHNOLOGY: HHK (ENERGY & ENVIRONMENT FRIENDLY)

CAPACITY: 50,000 PCS/DAY.

- **NB CNG Filling Station:** Kechuatoil, Rajshahi
580 m³/hr capacity
- **Supply, installation & commissioning of WTP, WWTP, STP, DWP, Rain Water Harvesting, Plumbing System, Drip Irrigation System, Solar Water Heating System** etc. at Saiham Tower, Gulshan-1, Dhaka. It is a LEED-Platinum building.
- **Commissioning** of Electrical system, Steam system, Flue system, Compressed Air system, HVAC system, Fuel system, Heat Recovery system, Cold water system, ETP & STP, Fire Alarm & Fighting system, Lightning Protection system, Earthing system etc. at **British American Tobacco**, Savar, Bangladesh.

Pharmaceuticals Projects:

WTP, PW System:

- ACI Healthcare Ltd., Sonargaon, Narayanganj.
- Beximco Pharma Ltd. (3rd Unit), Tongi, Gazipur.

Green projects (water & waste water system, Leed platinum/gold nominated):

- Saiham Tower, Gulshan Avenue, Dhaka.
- BTI Landmark Tower, Gulshan Avenue, Dhaka.

Air compressor:

- ACI Healthcare Ltd., Sonargaon, Narayanganj.

Industrial Services (Utility) System:

- Beximco Pharma Ltd. (3rd Unit), Tongi, Gazipur.

(Compressed Air System, Tower & Chilled Water System, Water Supply system, Steam & Condensate System, HVAC system, Lab Gas System etc.)

Company offered products & services

- ❖ Water Treatment Systems (WTS)
- ❖ Effluent Treatment Plant (ETP)
- ❖ Engineering Products
- ❖ Engineering Fabrication
- ❖ Boiler & Boiler Room Engineering
- ❖ Industrial Erection Works
- ❖ Heat Recovery Systems
- ❖ M & E Consultancy
- ❖ Industrial Planner
- ❖ Engineering Service

Water Treatment Systems

PEL provides water treatment solutions for all type of applications, from domestic equipment to industrial turnkey plants. Our wide range of technologies and extended know-how in all water-related sectors will guarantee you a cost-efficient solution meeting your water quality requirements. WTS product range includes:

- Oxidation chamber
- Multimedia filter
- Sand filter
- Iron filter
- Carbon filter
- Water Softener
- Reverse osmosis system
- Micron filter
- Drinking water plant
- Demineralization plant
- Electrical Deionization Unit
- UV & Ozone Generator
- Aeration system
- Clarifier
- Purified Water System



Pre-treatment, RO System, Mixed Bed System, Baraka Patenga Power Ltd.



Pre-treatment, Water Softener, RO System, EDI System, Orion Power Rupsha Ltd.



Pre-treatment, Water Softener, RO System, EDI System, Oxidation Chamber, United Mymensingh Power Ltd.



UF filter (WWTP), Saiham Tower



Raw water & Treated water Delivery Pump & Disc filter (Rain water Treatment plant) Saiham Tower



Water Treatment Plant, Saiham Tower

N.B: **Saiham Tower**, LEED Certification Compliant Green Building.



Drinking water system, Saiham Tower



WTP(Dialysis), Square Hospital



Purified Water distribution system, ACI Healthcare Ltd.



Pre-treatment, Water Softener, RO System, EDI System, Oxidation Chamber, Dhaka Southern Power Generation



Pre-treatment, Water Softener, RO System, EDI System, Oxidation Chamber, Dhaka Northern Power Generation



Pre-treatment, Water Softener, RO System, EDI System, Confidence Power Rangpur Ltd.



Flash & Flocculation Mechanism, Lamella Clarifier, Pre-treatment, Water Softener and RO System, Energypac Power Generation Ltd.



Pre-treatment, Water Softener, RO System, EDI System, Orion Power Sonargaon Ltd.



Pre-treatment, Water Softener, RO System, EDI System, Orion Power Sonargaon Ltd.



Pre-treatment, Water Softener, ACI Healthcare Ltd.



Pre-treatment, Water Softener, Beximco Pharmaceuticals (Unit-III) Ltd.



Pre-treatment, Water Softener, RO System, Asgar Ali Hospital



Pre-treatment, Water Softener, Oxidation Chamber, Envoy Textiles Ltd.



Pre-treatment, Water Softener, CEMEX Cement (BD) Ltd.



Pre-treatment, Water Softener, UV System, Givensee Foods & Essentials Ltd.



Pre-treatment, Water Softener, Oxidation Chamber, RO System, UV System, Square Hospitals Ltd.



Pre-treatment, Water Softener, Micron Filter, UV System, Columbia Washing Plant Ltd.



Pre-treatment, Water Softener, RO System, EDI System, UV System, Square Toiletries Ltd.



UF System (WWTP), BTI Tower



ACI Healthcare Ltd.



BTI Landmark, Gulshan Avenue (STP & WTP)

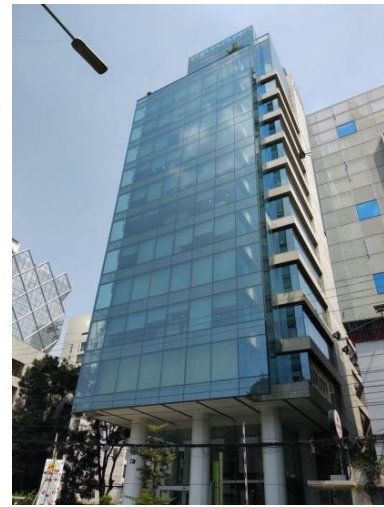

Saiham Tower, Gulshan Avenue



IL Bangla Ltd., Pre-treatment System

Effluent Treatment Plant

PEL is involved in offering a comprehensive range of Effluent and Sewage Treatment Plants. Our Effluent Treatment Plants provide effective solutions to effluent odor control, BOD reduction, aeration, clarification, phosphorous and nitrogen removal and more.

- ❑ Effluent Treatment Plant (ETP)
- ❑ Sewage Treatment Plant (STP)



Coats BD



Meghna knit



Disc Diffuser



FAB Media

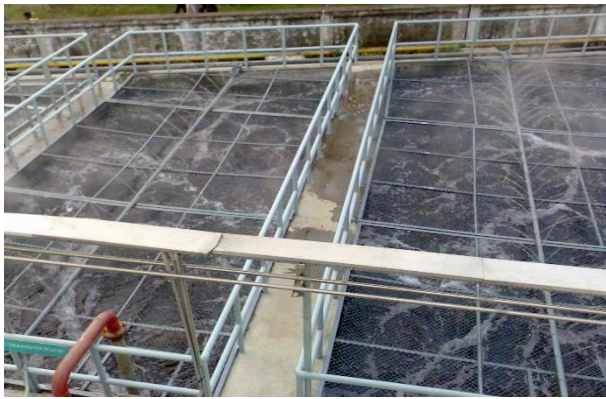

Equalization Tank



Filter Press



Filter Press, Saiham Tower



Settler ,BTI



STP, Saiham Tower

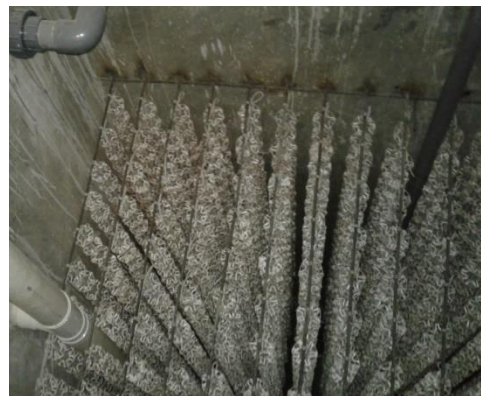

Aerobic Reactor, BTI

Engineering Products

PEL is associated with supplying all types of Electrical, Mechanical & Electro-Mechanical Engineering products from various renowned international brand.

- Water Treatment media/chemicals
- FRP Vessel & Filter
- Industrial pumps (All applications)
- Water Treatment System Media
- EDI Modules
- Water flowmeter
- Various kinds of valves & accessories
- Pipe & Fittings
- Structure Materials





CS Elbow

CS ERW/Seamless Pipes



Rock Wool Pipe Insulation

SS Fittings (Press type)

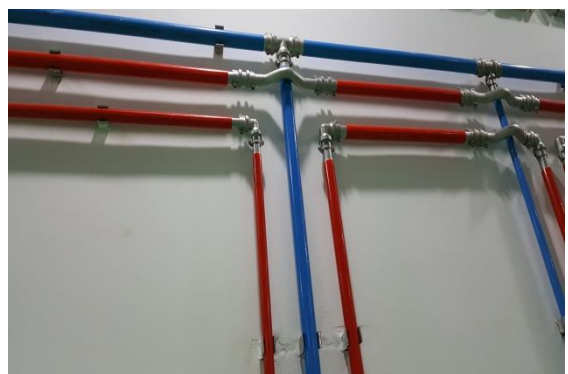

CS ERW/Seamless Pipes

SS Pipes (Press Type)



CS Fittings



SS Fittings (Press type)



SS Flanges



Boosting System



PUMA Air Compressor, Jamuna Group



PUMA Air Compressor, ACI Healthcare

Engineering Fabrication

We are one of the trustworthy service providers of an array of Fabrication Works. We have team of qualified professionals for the timely execution of all the services using high grade raw material. Our services are meticulously planned before their commencement and valued for their reliable & long serving life.

- Pressure vessel (ASME stamped or non-ASME)
- Air receiver tank
- Heat exchanger (process HE/economizer/Pre-heaters)
- Any kind of tank (air/water/oil)
- Other fabrication works provided design or sample is available





Boiler & Boiler Room Engineering

PEL do the work of supply, installation, commission of various types of Boiler from internationally renowned boiler manufacturers like Ross, Aktes, Greens, M.E. Energy etc. Besides, we do all the piping, ducting work related to boiler and boiler room.

- Water tube steam boiler
- Fire tube steam boiler
- Tubeless steam boiler
- Hot water generator
- Thermic oil heater
- Husk/Coal/Bagasse/wood fired steam boiler
- Waste Heat recovery boiler



WHRB, Baraka Power



Aux. Boiler Erection Works, Orion Power



2TPH Steam Boiler, Towa



Oil Fired Steam Boiler, Greens



4TPH Steam Boiler, Towa Personal Protective Device

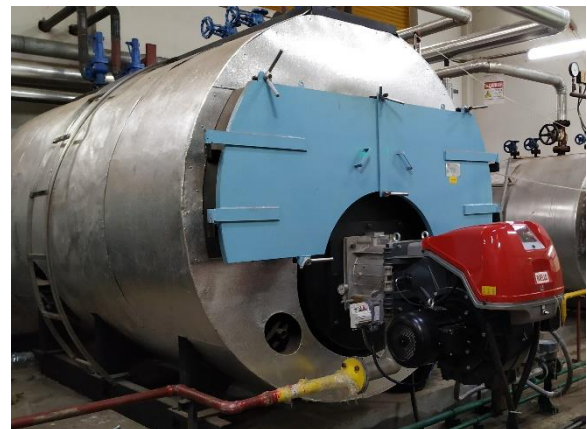



2 Set 4 TPH Aktes Steam Boiler, ACI Healthcare Ltd.



Chimney, ACI Healthcare Ltd.



Exhaust Gas Boiler, Confidence Power Rangpur Ltd.

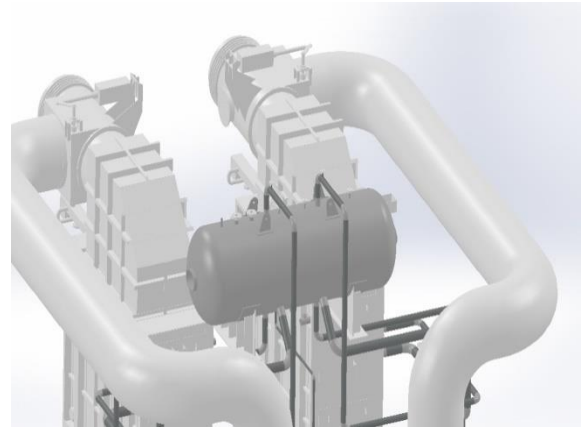
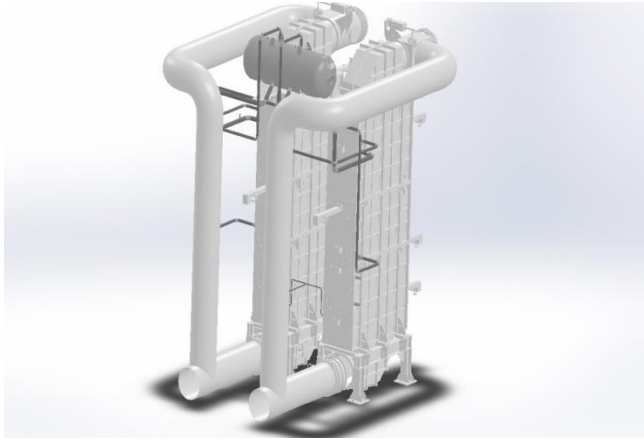

3D view of Greens Boiler

Industrial Erection Works

- Industrial Machinery Installation, commissioning & overall Erection
- Electrical wiring and equipment installation
- Hot & Cold piping for water, steam and Oil
- Compressed air piping with filter fitting
- Making connection with all auxiliary machine with main machine
- WTP, ETP, Boiler & boiler burner installation, commission and service
- Deep tube well
- Substation works
- Generator, compressor & cooling tower installation, commission and service
- Food & beverage industry



BPPL 53.3MW HFO Power Plant



CPCL 50MW HFO Power Plant



Textile Washing Ind.



Meghnaghat 100 MW HFO Power Plant



Confidence Power Rangpur Ltd.



United Ashugonj power Ltd.



Turbine, Alternator, Condensor Erection work, Orion Power Sonargaon Limited





Silo Erection work at Akij Particle Board Mills



Cooling Tower Erection work, UMPL



Cooling System Erection work, UMPL



EGB Duct Boiler, OPRL



EGB Boiler installation work, OPRL



Confidence Power Bogra Limited
(Installation of Equipment)



100 CMH Deep Tube well, CPRL



Erection Work at Akij Bakers Ltd



Generator Erection Work at American & Efid Ltd.

Heat Recovery Systems

At **PEL**, we are dedicated to providing optimum heating and cooling solutions that are simple, efficient and customized to meet the most stringent process requirement. We reciprocate our customer's desire for "Value for money" services by fostering a business relationship that looks much beyond sales and after sales service.

- ✓ Heat recovery systems on Gas turbine
- ✓ Jacket Water Heat Recovery
- ✓ Heat Recovery from Boiler Blowdown
- ✓ Heat Recovery from Steam Condensate System
- ✓ Heat recovery chiller
- ✓ Heat recovery thermal oil heater
- ✓ Hybrid Power Generation Systems



Baraka Patenga Power Limited (54 MW HFO Power Plant / 3.3 MW Co-generation.)



Confidence Power Rangpur Limited (113 MW HFO Power Plant / 6.3 MW Co-generation.)



United Mymensingh 200 MW HFO (2x6.6 MW Cogen BOP)



United Ashuganj 200 MW Modular CCPP (16 MW Cogen BOP)

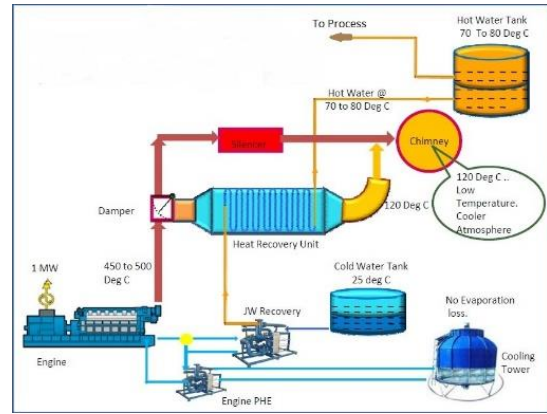

Waste Heat Recovery Hot Water system at Square Hospitals Ltd.



Orion Power Rupsha Limited (105 MW HFO Power/ 6.6 MW Cogen turnkey erection)



United Jamalpur 115 MW HFO Power (7.5 MW Co-gen BOP with Cooling System)



5 Ton, 6 Ton, 7 Ton (two) Economiser installed at Envoy Textile, Jamirdia, Bhaluka, Mymensingh



Economiser installed at Montex Fabrics Ltd. Nayapara, Kashimpur, Gazipur, Dhaka

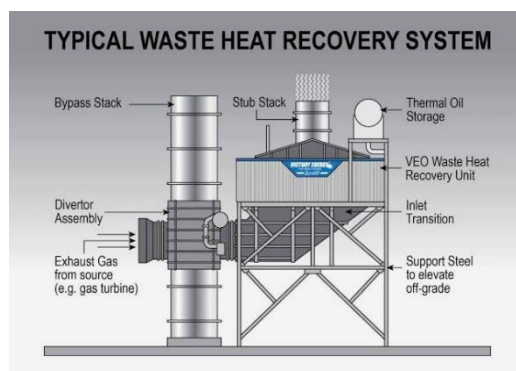

1 waste heat recovery saturated steam boiler at Chaity Knit Composite Ltd, Sonargaon, Narayanganj (3 Gas engine waste heat connected to a common EGB)

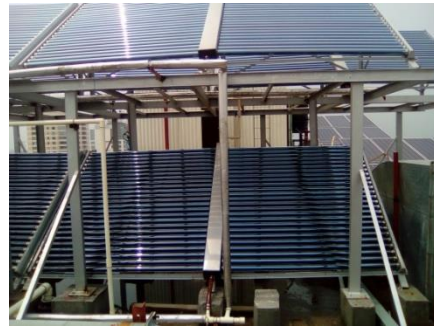

Solar Water Heating System, Saiham Tower

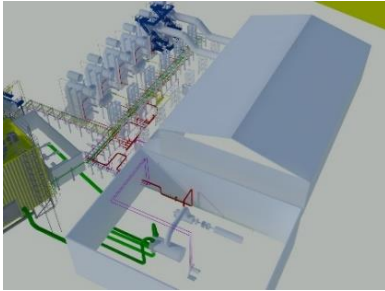

Karnaphully Power Limited 110 MW HFO (Co Generation BOP-Design, Drawing, Erection, Supply)



03 Nos. 15 m³/h @65°C, Heat Recovery Hot Water system from Engine Jacket Water at Montex Fabrics Ltd, Nayapara, Kashimpur, Gazipur.

M & E Consultancy



- ✚ Industrial business concept planning, market survey, designing
- ✚ Main & auxiliary machines Installation & commission turnkey basis
- ✚ Commissioning of industrial plant
- ✚ Management & Environmental consultancy (IEE, EIA, EMP, QMS – ISO 9001:2008, HACCP, EMS – ISO 14000, WRAP certification)
- ✚ Process heat auditing and efficiency improvement



Commissioning of BATB Plant, British American Tobacco Bangladesh, Savar, Dhaka



Confidence Power Rangpur Limited, 113 MW HFO Power Plant, Rangpur.

Engineering Service

PEL is well facilitated with its expert servicing team in Electrical and Mechanical sector. All our product related services, maintenance and after sales service is available throughout the year.

- ❖ WTS, ETP, STP related all types of servicing
- ❖ Boiler & Boiler room services
- ❖ Electrical & Mechanical services of Pumps, Motors, Valves etc.
- ❖ After sales service of all the products
- ❖ Spare parts supply of all electro-mechanical instruments

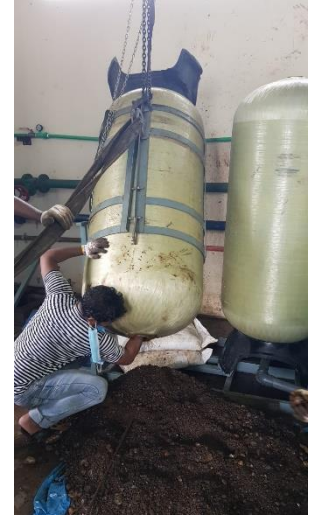



Industrial Planner

- ❖ Program management, master planning, design, procurement, engineering and construction management.
- ❖ Development, improvement, implementation of integrated systems of people, money, knowledge, information, equipment, energy, materials etc.
- ❖ EPC of Automatic brick field, Cottage, Filling Station, Pre-fabricated building etc.



EPC, Thangerban, Mouchak, Gazipur Cottage



EPC, N B CNG Filling station, Rajshahi



EPC, RABL_50K HHK Plant



Pre-Fab Steel Building, Knittex Dresses

List of Key Personnel

Sl.	Name	Designation
1	Engr. Ziaur Rahman	Managing Director
2	Engr. Md. Ali Asraf	Director
3	Engr. Toriqul Islam	Director
4	Md. Tuhin Sheikh	Head of Sales & Marketing
5	Engr. Abdul Baki	Chief Technical Advisor
6	Engr. Gautam Prasad Dutta	Technical Advisor
7	Md.Ilias Hossain	CEO
8	Md. Fazidul Islam	AGM (Sales & Service)
9	Sanwarul Islam	Sr. Manager (Factory)
10	Engr. Kazi Md. Yasin Ullah (Sunny)	Manager (R&D)
11	Md. Sipiurul Islam	Asst. Manager (Service)
12	Md. Shariful Islam	Asst. Manager (Sales & Marketing)
13	Md. Mahmudul Hasan	Asst. Manager (Operation)
14	Engr. Mrinal Kanti Mondal	Sr. Engineer (Operation)
15	Engr. Asif Ali	Sr. Engineer (Design)
16	Engr. Imrul Kaiesh	Sr. Engineer (R&D)
17	Engr. Rafiuzzaman	Sr. Engineer (Service)
18	Engr. Kazi Md. Momtatahul Ulah	Sr. Engineer (Sales & Marketing)
19	Md. Md. Yeasin	Sr. Engineer (R&D)
20	Md. Tuhin Ali	Sr. Engineer (Operation)
21	Md. Mahmudur Rahman	Sr. Engineer (Operation)
22	Shekh Farid	Sr. Engineer (Sales & Service)
23	Md. Rafiqul Islam	Sr. Engineer (Sales)
24	Md. Azharul Islam Khan	Engineer (Sales & Marketing)
25	A.B Haider	Sr. Executive (Sales & Marketing)
26	Md. Ripon Sarker	Engineer (Sales & Service)

27	Md. Tushar Mondol	Engineer (Sales & Service)
28	Sabbir Ahmeed Soheel	Sr. Executive (Account)
29	Md. Abu Shahid	Deputy Manager (Commercial)
30	Md. Monirul Haque	Sr. Executive (Admin)
31	Lothfor Rahman	Asst. Manager (Procurement & Store)
32	Md. Masudur Rahman	Executive (Procurement)
33	Mamun Rashid	Store in Charge
34	Nayan Mia	Sr. Technician
35	Md. Samad	Foreman
36	Chand Mia	Foreman

COMPANY ORGANOGRAM

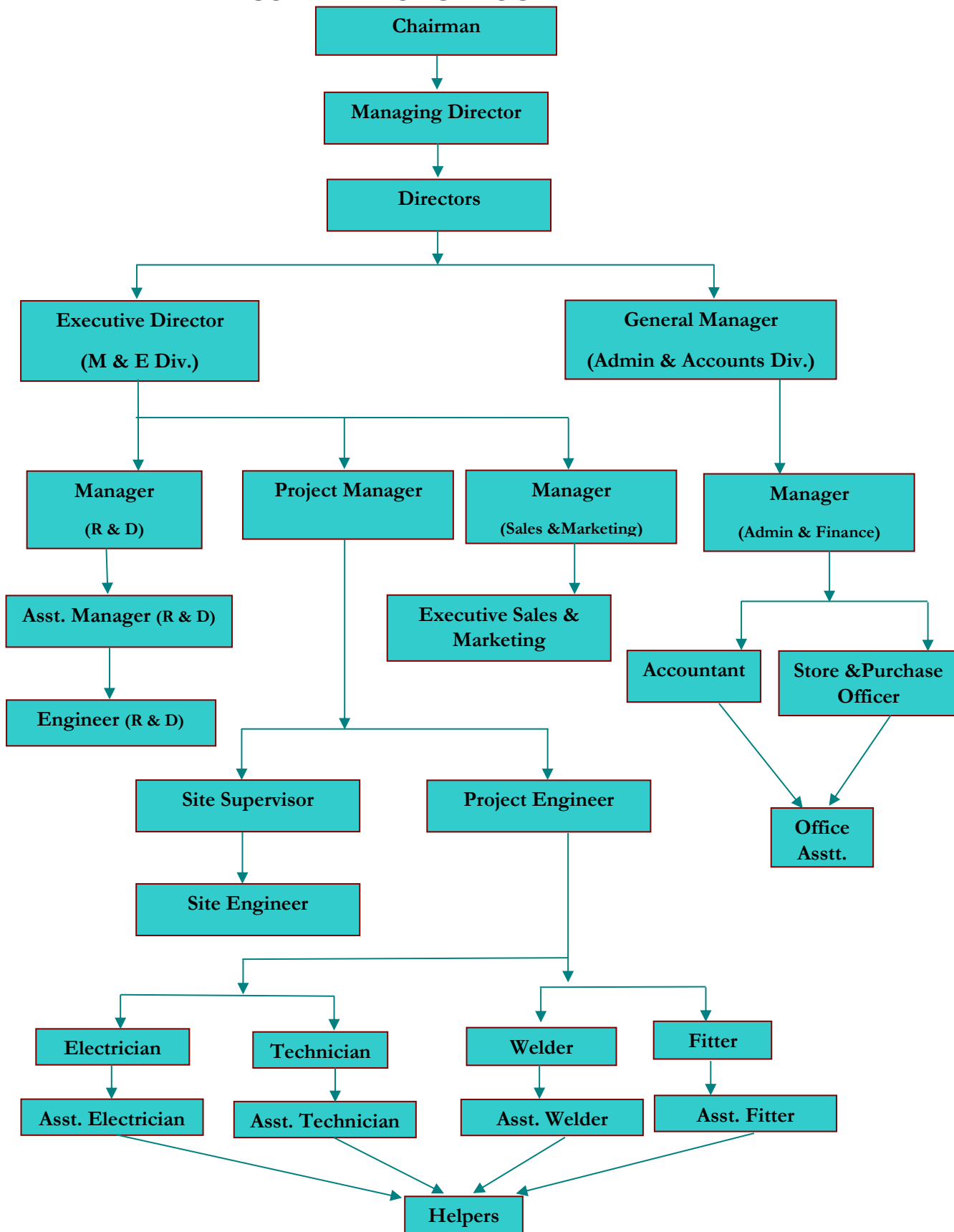

ENGR. ZIAUR RAHMAN



- Designation: Managing Director
- Profession: Business
- Educational Qualification:
B.Sc. Engineering. (Mech.), BUET; FIEB (F-11741), MBA.

- Field of Experience:
19 Years engineering experience over industrial erection work, production & maintenance job, supervision of plant & machinery, industrial product design & manufacturing, engineering fabrication, designing of different thermal equipment, water and waste quality management system (WTP/ETP/STP/PW system/WFI) & its various application system, turn-key erection & fabrication projects.

- Present Address:
Office – 389/B, DIT Road, L-8, MG Tower, West Rampura, Dhaka-1219.
Residence – House: B-99, Road-1, 4thFloor, Mohanagar Project, Rampura, Dhaka.

- Permanent Address:
Holding No. 1473/B, Hafez Commissioner Road, Saraipara, Pahartoli, Chittagong-4202, Bangladesh.

- Contact Details:
CELL: +88 01819 629231, +88 01313 019900
PHONE: +88 02 9343024, 9336992
FAX: +88 02 9338076
Email: zia@pivotengg.com, pivotengg@gmail.com
URL: www.pivotengg.com

ENGR. ALI ASRAF

- Designation: Director
- Profession: Business
- Educational Qualification:
B.Sc. Engineering. (Mech.), BUET; FIEB (F-11742), MBA.



- Field of Experience:
19 Years engineering experience over quality management system, Industrial Products & Process design & marketing, energy auditing and energy saving projects, cogeneration/tri-generation system, process heating and cooling system, industrial utility system (Boiler & Steam system, Air compressor & compressed air system, Water distribution system), EPC and turn-key jobs.
- Present Address:
Office – 389/B, DIT Road, L-8, MG Tower, West Rampura, Dhaka-1219.
Residence - House-462, 5th Floor, Greenway, Noyatola, Moghbazar, Dhaka-1217.
- Permanent Address:
Village- Karnakhali, P.O: Mirjapur; P.S-Shibganj, Dist.-Chapai Nawabganj, Bangladesh.
- Contact Details:
CELL: +88 01715297538
PHONE: +88 02 9343024, 9336992
FAX: +88 02 9338076
Email: asraf@pivotengg.com, pivotengg@gmail.com
URL: www.pivotengg.com

ENGR. TORIQUL ISLAM



- Designation: Director
- Profession: Business
- Educational Qualification:
B.Sc. Engineering, RUET, FIEB (F-11719), MBA.

- Field of Experience:
18 Years engineering experience over different industries machineries maintenance, Marketing of engineering fabrication & customized products, Water and waste water treatment system for different fields and application, turn-key erection & fabrication projects.

- Present Address:
Office – 389/B, DIT Road, L-8, MG Tower, West Rampura, Dhaka-1219.
Residence - House-82, Block-B, Road-7, South Banasree, Dhaka-1219.

- Permanent Address:
Vill.-Gachiadoulatur, P.O- Parankhali P.S- Bheramara, Dist.- Kushtia.

- Contact Details:
CELL: +88 01914012318, +88 01313 019901
PHONE: +88 02 9343024, 9336992
FAX: +88 02 9338076
Email: toriqul@pivotengg.com, pivotengg@gmail.com
URL: www.pivotengg.com

ENGR. MD. ABDUL BAKI



- Designation: Chief Technical Advisor
- Profession: Business
- Educational Qualification:
B.Sc. Engineering. (Electrical & Electronics)
- Field of Experience:
Total 39 years' experience in **Zia Fertilizer Company Limited, Ashuganj, B. Bria & Karnaphuli Fertilizer Company Limited, Chittagong**, over erection, Installation, testing & commissioning work of all electrical installations, maintenance & trouble shooting work of Generators, Motors, Switchgear, transformer, Motor Control Centers, Central HVAC System, Fire alarm system, Electrical Load Management System, UPS & battery chargers etc.
- Present Address:
Office – 389/B, DIT Road, L-8, MG Tower, West Rampura, Dhaka-1219.
Residence – E-30/7, Road # 8, North Bonojshree, Khilgao, Dhaka- 1219.
- Permanent Address:
Village: Bangabaria, P.O.: Naogaon; P.S-Naogaon, Dist.- Naogaon.
- Contact Details:
CELL: +88 01730323114
PHONE: +88 02 9343024, 9336992
FAX: +88 02 9338076
Email: pivotengg@gmail.com, abdulbakittl@gmail.com

ENGR. GAUTAM P. DATTA



- Designation: Technical Advisor
- Educational Qualification:
B.SC. Engineering. (Mechanical), CUET, 1976.
- Field of Experience:
Total 44 years' engineering experience in

British American Tobacco, Savar, Bangladesh on Commissioning & Design of Utility Systems (Steam generation, distribution & condensate return, Chimney design, Diesel power generation Compressed air distribution, ETP, WTP, RO & water distribution, Waste heat recovery, Fuel Oil storage & distribution, Fire detection & fighting, HVAC & Chiller.

Synthetic Yarn Factories (Kader Synthetic Fibers, Gazipur & Modern Poly Industries, Ctg) on Project Design/Implementation/Erection & Installation/Maintenance on Textile m/c's & Utility equipment- Central HVAC & Chiller, WTP, RO, Compressed Air, Power Gas generator, Waste heat recovery from generator

Bangladesh Chemical Industries Corporation (Karnaphuli Paper Mills, Ctg., Celpap AB, Sweden, Sylhet Pulp & Paper Mill, Chattak, Dhaka Match Factories, Dhaka & Magura Paper Mill, N'gonj) on Maintenance/Project Implementation/Erection/Installation, of Plant machineries & equipment & Utilities

- Present Address:
House-21, Road-16, Sector-04, Uttara, Dhaka
- Contact Details:
CELL: +88 01313 019903
PHONE: +88 02 9343024, 9336992
FAX: +88 02 9338076
Email: pivotengg@gmail.com, technical@pivotengg.com
URL: www.pivotengg.com

MD. TUHIN SHEIKH



- Designation: Head of Sales & Marketing
- Educational Qualification:
MBA Major in Marketing, AUB. Dhaka

- Field of Experience:
18 Years marketing experience over different industrial machineries, & Marketing team leading capacity. Specialization on Air compressor, Steam boiler, Water pump, Generator & Auto rice machine.

- Present Address:
House-11/3, Road-SBC Lane, Gandaria, Dhaka-1204

- Permanent Address:
Vill- Kabutor Kholā, P.O- vaghokul, Thana-Sreenagar, Munshigonj

- Contact Details:
CELL: +88 01313019902
PHONE: +88 02 9343024, 9336992
FAX: +88 02 9338076
Email: pivotengg@gmail.com, tuhin@pivotengg.com
URL: www.pivotengg.com

ENGR. SHEIKH NAZMUL TARIQ

- Designation: Director Technical
- Educational Qualification:
B.Sc. in Engineering, BUET, MIEB, BSME.

- Field of Experience:
19 Years engineering experience over different industries machineries maintenance, Design, Installation & Commissioning of Power generation plant, Central HVAC system, Water Treatment plant, Boiler & Hot Water System, ETP, Commercial Type Laundry, Kitchen, Lifts & Escalators, Medical Gas System.

- Present Address:
Office – 389/B, DIT Road, L-8, MG Tower, West Rampura, Dhaka-1219.
Residence – 32/B-3 East Nayatola, Moghbazar, Dhaka – 1217
- Permanent Address:
32/B-3 East Nayatola, Moghbazar, Dhaka – 1217

- Contact Details:
CELL: +88 01745706716
PHONE: +88 02 9343024, 9336992
FAX: +88 02 9338076
Email: pivotengg@gmail.com
URL: www.pivotengg.com

ENGR. MD. ILIAS HOSSAIN



- Designation: CEO
- Profession: Business
- Educational Qualification:
B.Sc. Engineering, CUET

- Field of Experience:
29 years of home and abroad professional experience on Business decision, SWOT analysis, Feasibility Study, Project Panning, Project Profile Preparation, Project Financing, Preparation of Financial Statement, Project Estimation and Costing, Project Completion Schedule, Gantt Chat, PERT & CPM Analysis, Installation, Erection, Testing & Commissioning, Preparation of Project Development Schedule, Preparation of Reports on Project Status and Preparation of Action Plan for Proper & on time Implementation of project, Preparation of scheduled & Preventive Maintenance Schedule and Spare Parts Planning, Control & Maintain Inventory for proper maintenance of modern DCS controlled Power Plants (HFO/Diesel/ Gas Engine, STG & CCPP), Utility Plant, Petroleum Oil Refinery, Sugar Refinery, WTP & ETP, Municipal Solid Waste (MSW) to Wealth and Modern One-Composite Textile Mills.

- Present Address:
Office – 389/B, DIT Road, L-8, MG Tower, West Rampura, Dhaka-1219.
Residence - Oriental Palace, Flat # C-2 House #85, Road # 12A,
Dhanmondi, R/A, Dhaka -1209, Bangladesh

- Permanent Address:
Vill: Akailkura, Union: Kamalpur, Post: Kamalpur Dist: Moulvibazar, Sylhet

- Contact Details:
CELL: +88 01711595980,
PHONE: +88 02 9343024, 9336992
FAX: +88 02 9338076
Email: pivotengg@gmail.com, ceo@transtltd.com
URL: www.pivotengg.com

MD. FAZIDUL ISLAM



- Designation: AGM (Sales & Service)
- Educational Qualification:
Diploma in Engineering (Power)
- Field of Experience:
22 Years engineering experience over industrial erection work, production & maintenance job, supervision of plant & machinery, industrial product manufacturing & its application.
- Present Address:
536/3, Middle Monipur, Mirpur, Dhaka.
- Permanent Address:
Village-Mondolpara, P. O+P.S-Pabna, Dist.-Pabna.
- Contact Details:
CELL: +88 01313 019904
PHONE: +88 02 9343024, 9336992
FAX: +88 02 9338076
Email: pivotengg@gmail.com, operation@pivotengg.com
URL: www.pivotengg.com

MD. SANWAR HOSSAIN



- Designation: Sr. Manager (Factory)
- Educational Qualification:
Diploma in Mechanical Engineering
- Field of Experience:
20 Years engineering experience over water & waste water systems, industrial erection work, production & maintenance job, supervision of plant & machinery, industrial product manufacturing & its application.

- Present Address:
347/1, East Nakhhal Para, Dhaka.

- Permanent Address:
Vill: Ray Para, P.O: Rajshahi Court, P.S: Rajpara, Dist: Rajshahi.

- Contact Details:
Cell: +88 01313 019905
PHONE: +88 02 9343024, 9336992
FAX: +88 02 9338076
Email: pivotengg@gmail.com, operation@pivotengg.com
URL: www.pivotengg.com

KAZI MD. YASIN ULLAH



- Designation: Manager (R&D)
- Educational Qualification:
B. Sc. In Electrical and Electronics Engineering
- Field of Experience:
9 Years engineering experience over industrial electrical work, maintenance job, supervision of plant & machinery, project management, designing of electro-mechanical jobs, cogeneration plant etc.
- Present Address:
5th Floor, House: 117, Block: B, Road No.: 01, Mohanogor Project, West Rampura, Dhaka.
- Permanent Address:
Holding:2258, Hazi Belayet Ali Lane, Pahartoli, Chittagong-4202, Bangladesh.
- Contact Details:
CELL: +88 01313 019906
PHONE: +88 02 9343024, 9336992
FAX: +88 02 9338076
Email: pivotengg@gmail.com, rnd@pivotengg.com
URL: www.pivotengg.com

MD. SIPIARUL ISLAM



- Designation: Asst. Manager (Service)
- Educational Qualification:
Diploma in Mechanical Engineering

- Field of Experience:
18 Years engineering experience over installation of water & waste water equipment, different industries machineries maintenance & servicing.

- Present Address:
347/1, East Nakhhal Para, Dhaka.

- Permanent Address:
Vill: Ray Para, P.O: Rajshahi Court, P.S: Rajpara, Dist: Rajshahi.

- Contact Details:
CELL: +88 01313 019908
PHONE: +88 02 9343024, 9336992
FAX: +88 02 9338076
Email: pivotengg@gmail.com, service@pivotengg.com+88 01313 019906
URL: www.pivotengg.com

MD. SHARIFUL ISLAM



- Designation: Asst. Manager (Sales & Marketing)
- Educational Qualification:
Diploma in Mechanical Engineering

- Field of Experience:
14 Years engineering experience over water & waste water systems, Fire Fighting System, industrial erection work, different industries machineries Marketing & sales.

- Present Address:
Residence – House-C/72, 2nd Floor, Road-5, Mohanagar Project. Rampura, Dhaka.
- Permanent Address:
Vill: Gachiadoulatur, P.O: Parankhali, P.S: Bheramara, Dist: Kushtia.

- Contact Details:
CELL: +88 01313 019907
PHONE: +88 02 9343024, 9336992
FAX: +88 02 9338076
Email: pivotengg@gmail.com, sales@pivotengg.com
URL: www.pivotengg.com

MD. MAHMODUL HASAN



- Designation: Asst. Manager (Operation)
- Educational Qualification:
Diploma in Engineering (Power)

- Field of Experience:
9 Years engineering experience over industrial erection work, production & maintenance job, supervision of plant & machinery, industrial product manufacturing & its application.

- Present Address:
21/C, Road-8, Nakhalpara, Dhaka.

- Permanent Address:
Village: Tankathlasen, P. O+P.S-Namkathlasen, Dist:Mymensingh.

- Contact Details:
CELL: +88 01313 019909
PHONE: +88 02 9343024, 9336992
FAX: +88 02 9338076
Email: pivotengg@gmail.com, operation@pivotengg.com
URL: www.pivotengg.com

MD. ASIF ALI



- Designation: Asst. Manager (R&D)
- Educational Qualification:
B. Sc. In Mechanical Engineering
- Field of Experience:
7 Years engineering experience in mechanical design, AutoCAD 2D and 3D drafting, 3D modeling of piping systems using AutoCAD plant 3D.
- Present Address:
577, West Nakhalpara, Tejgaon, Dhaka-1215
- Permanent Address:
Village: Rahimabad Uttarpara, Post Office: Rahimabad-5801, Police Station: Sahjahanpur, District: Bogra.
- Contact Details:
CELL: +88 01313 019920
PHONE: +88 02 9343024, 9336992
FAX: +88 02 9338076
Email: pivotengg@gmail.com, rnd@pivotengg.com
URL: www.pivotengg.com

MRINAL KANTI MONDAL



- Designation: Sr. Engineer (Operation)
- Educational Qualification:
B.Sc. in Electrical and Electronics Engineering
- Field of Experience:
8 Years engineering experience over water & waste water systems, different industries machineries installation, maintenance & servicing.
- Present Address:
Square Master Bari, House-10, Bhaluka, Mymensingh, Bangladesh.
- Permanent Address:
Vill: Ruprampur, Post: Thukra, Thana: Dumuria, Dist: Khulna.

- Contact Details:
CELL: +88 01313 019912
PHONE: +88 02 9343024, 9336992
FAX: +88 02 9338076
Email: pivotengg@gmail.com, operation@pivotengg.com
URL: www.pivotengg.com

MD. IMRUL KAIESH

- Designation: Sr. Engineer (R&D)
- Educational Qualification:
B.Sc. in Electrical and Electronics Engineering
- Field of Experience:
5 Year engineering experience over different industries machineries installation, maintenance & servicing.
- Present Address:
Present Address: Address: 302/A, Olon Road, Rampura, Dhaka-1219.
- Permanent Address:
Vill: Adompur, Post: Bargachihat, Thana: Bholahat, Dist: Chapai Nawabganj.
- Contact Details:
CELL: +88 01313 019913
PHONE: +88 02 9343024, 9336992
FAX: +88 02 9338076
Email: pivotengg@gmail.com, rnd@pivotengg.com
URL: www.pivotengg.com



MD. RAFIUZZAMAN

- Designation: Sr. Engineer (Service)
- Educational Qualification:
B.Sc. in Electrical and Electronics Engineering
- Field of Experience:
3.5 Years engineering experience on Commissioning, installation, maintenance & servicing Electrical Sub-station, Earthing & Lightning, Steam generation, Diesel power generation, Compressed air.



- Present Address:
House-441/2/B, 5th floor, Senpara, Parbota, Mirpur-10, Dhaka-1216.
- Permanent Address:
Village: Kadoa, P. O: Kadoa, P.S: Sujanagar, Dist: Pabna, Bangladesh.
- Contact Details:
CELL: +88 01313 019919
PHONE: +88 02 9343024, 9336992
FAX: +88 02 9338076
Email: pivotengg@gmail.com, service@pivotengg.com
URL: www.pivotengg.com

KAZI MD. MOMTAHATUL ULAH

- Designation: Sr. Engineer (Sales & Marketing)
- Educational Qualification:
B. Sc. In Electrical and Electronics Engineering
- Field of Experience:
3.5 Year engineering experience over different industries machineries, Secondary Power Plant, Compressed air distribution, ETP, WTP, installation, maintenance & servicing.
- Present Address:
5th Floor, House: 117, Block: B, Road No.: 01, Mohanogor Project, West Rampura, Dhaka.
- Permanent Address:
Holding No.: 1655/2258, Hazi Belayet Ali Lane, Pahartali, Chittagong.
- Contact Details:
CELL: +88 01313 019914
PHONE: +88 02 9343024,
FAX: +88 02 9338076
Email: pivotengg@gmail.com, sales@pivotengg.com
URL: www.pivotengg.com



MD. YEASIN

- Designation: Sr. Engineer (R&D)
- Educational Qualification:
Diploma in Civil Engineering
- Field of Experience:
4 Years in electro-mechanical drafting jobs. Auto CAD 2D, 3D & Structural Drafting (Professional), 3ds Max, Revit, Sketch-Up, Estimate & BOQ format.
- Present Address: Address: 302/A, Olon Road, Rampura, Dhaka-1219.
- Permanent Address:
Vill: Kurchap, P.O-Kurchap, p/s: Dabidwer, Dist: Comilla-3510.
- Contact Details:
CELL: +88 01313 019915
PHONE: +88 02 9336992
FAX: +88 02 9338076,
Email: pivotengg@gmail.com, rnd@pivotengg.com
URL: www.pivotengg.com



MD. TUHIN ALI

- Designation: Sr. Engineer (Operation)
- Educational Qualification:
Diploma in Civil Engineering
- Field of Experience:
4 Years engineering experience over production & maintenance job, supervision of plant & machinery, industrial product manufacturing.
- Present Address:
House: 40, Road:10, Block: H, Mirpur-2, Dhaka- 1216.
- Permanent Address:



Village-Meghnapura, Post Office: Bahadurpur, Police Station: Bheramara,
District: Kushtia

- Contact Details:
CELL: +88 01313 019916, PHONE: +88 02 9336992
FAX: +88 02 9338076
Email: pivotengg@gmail.com, operation@pivotengg.com
URL: www.pivotengg.com

MD. MAHMUDUR RAHMAN



- Designation: Sr. Engineer (Operation)
- Educational Qualification:
Diploma in Electrical Engineering
- Field of Experience:
4 Years engineering experience over field work, production & maintenance job, supervision of plant, industrial product manufacturing.
- Present Address:
2nd Floor, House: 98, Block: D, Road No.: 04, Mohanogor Project, West Rampura, Dhaka.
- Permanent Address:
Village-Gachia Doulatpur, Post Office: Paran Khali, Police Station: Bheramara, District: Kushtia
- Contact Details:
CELL: +88 01313 019917, PHONE: +88 02 9336992
FAX: +88 02 9338076
Email: pivotengg@gmail.com, operation@pivotengg.com
URL: www.pivotengg.com

MD. AZHARUL ISLAM KHAN



- Designation: Engineer (Sales & Marketing)
- Educational Qualification:
B.sc in Electrical & Electronics
- Field of Experience:
2 Years engineering experience over field work, production & maintenance job, supervision of plant, safety engineer, telecom & broadcasting.
- Present Address:
74/1, Free School Street, Kathal Bagan, Kalabagan, Dhaka.
- Permanent Address:
Village- Baliadi, Post Office: Kaliakair, District: Gazipur
- Contact Details:
CELL: +88 01313 019923, PHONE: +88 02 9336992
FAX: +88 02 9338076
Email: pivotengg@gmail.com, sales@pivotengg.com
URL: www.pivotengg.com

SEKH FARID



- Designation: Sr. Engineer (Sales & Service)
- Educational Qualification:
B.sc in Electrical & Electronics
- Field of Experience:
8 Years engineering experience over Boiler installation, commissioning & maintenance job, supervision of plant & garments machineries
- Permanent Address:
Village- Gouripur, Post Office: Baluchara, Police Station: Kalmakanda,
District: Netrokona
- Contact Details:
CELL: +88 01313 019935, PHONE: +88 02 9336992
FAX: +88 02 9338076
Email: info@pivotengg.com, URL: www.pivotengg.com

MD. RIPON SARKAR

- Designation: Engineer (Sales & Marketing)
- Educational Qualification:
B.sc in Electrical & Electronics
- Field of Experience:
3 Years engineering experience on Commissioning, installation aspects on Service, Repair of Air Compressors, WTP, Boiler from all major brands.
- Present Address:
337/2, Tv Road East Rampura -1219, Rampura Dhaka.
- Permanent Address:
Village- Aziznagar, Post: Aziznagar, Thana: Tetulia, District: Panchagarh.
- Contact Details:
CELL: +88 01313 019932, PHONE: +88 02 9336992
FAX: +88 02 9338076
Email: pivotengg@gmail.com, sales@pivotengg.com
URL: www.pivotengg.com



A.B HAIDAR

- Designation: Sr. Executive (Sales & Marketing)
- Educational Qualification:
Master of Social Science (Economics)
- Field of Experience:
4 Years engineering experience over Sales & Marketing Boiler, Air Compressor, WTS and Media
- Permanent Address:
Vil: Madhobpur, post: Bahadurpur, p/s: Bheramara, Dist: Kushtia.
- Contact Details:
CELL: +88 01313 019931, PHONE: +88 02 9336992
FAX: +88 02 9338076
Email: info@pivotengg.com, URL: www.pivotengg.com



MD. RAFIQUL ISLAM



- Designation: Sr. Engineer (Sales)
- Educational Qualification:
B.sc in Electrical & Electronics
- Field of Experience:
18 Years engineering experience over field work, production & maintenance job, supervision of plant, site engineer, sales and marketing over boiler, compressor, steam engineering.
- Present Address:
Faridpur Bhaban, 312/7/2/1, Lalkutir, Tolabagh, 3rd Gate, Mirpur-01, Dhaka-1216
- Permanent Address:
Village- Kulchar, Post Office: Bailakhali, Police Station: Airport-Babuganj, District: Barishal
- Contact Details:
CELL: +88 01313 019936, PHONE: +88 02 9336992
FAX: +88 02 9338076
Email: pivotengg@gmail.com, URL: www.pivotengg.com

SABBIR AHMMED SOHEL



- Designation: Sr. Executive (Accounts)
- Educational Qualification:
BBS, MBS, LLB, CA CC
- Field of Experience:
6 Years' experience in accounts & finance
- Present Address:
GP Ga-26, Mohakhali, Dhaka
- Permanent Address:
New Khairtala, Jessore sadar, Jessore

- Contact Details:
CELL: +88 01313 019933
PHONE: +88 02 9336992
FAX: +88 02 9338076
Email: pivotengg@gmail.com, accounts@pivotengg.com
URL: www.pivotengg.com

MD. ABU SHAHID

- Designation: Deputy Manager (Commercial)
- Educational Qualification:
MBA (Accounting & information systems)
- Field of Experience:
8 Years in management & accounting.
- Present Address: Address: House # 07, Road # 10, Block # 11/C, Mirpur, Dhaka-1216.
- Permanent Address:
Vill: Madhobpur, post: Bahadurpur, p/s: Bheramara, Dist:Kushtia
- Contact Details:
CELL: +88 01313 019922,
PHONE: +88 02 9336992
FAX: +88 02 9338076,
Email: pivotengg@gmail.com, commercial@pivotengg.com
URL: www.pivotengg.com



MD. MONIRUL HAQUE

- Designation: Executive (Admin)
- Educational Qualification:
MBS (Masters of Business Studies)
- Field of Experience:
2 Years in management & accounting.
- Present Address:
House: 30, Road: 01, Block: C, Mirpur-12, Dhaka- 1216.



- Permanent Address:
Village-Islampur, Post Office: Golapnagar Police Station: Bheramara,
District: Kushtia
- Contact Details:
CELL: +88 01313 019911, PHONE: +88 02 9336992
FAX: +88 02 9338076
Email: pivotengg@gmail.com, admin@pivotengg.com
URL: www.pivotengg.com

MD. LOTHFOR KHAN

- Designation: Asst. Manager (Procurement & Store)
- Educational Qualification:
B. Com. (pass)
- Field of Experience:
8 years' experience over Engineering products purchase & Store keeping.
- Present Address:
House-33, Road-03, Block-D, 2nd floor, Mohanagar Project, Rampura,
Dhaka-1219.
- Permanent Address:
Village: Alongi, P. O+P.S: Kumarkhali, Dist: Kushtia.
- Contact Details:
Cell: +88 01313 019910
PHONE: +88 02 9343024, 9336992
FAX: +88 02 9338076
Email: pivotengg@gmail.com, procurement@pivotengg.com
URL: www.pivotengg.com



OFFICE INFRASTRUCTURE & LIST OF EQUIPMENT

- 6500 sft, space for the operational bodies.
- Well decorated & Comfortable Office Environment for the managements & staff's bodies
- Latest E-communication system also with Telephone, mobile & fax.
- 13 computers interlinked each other with Intranet & Internet facilities.

In-House Logistics Hardware

Desktop PC Core i7-9700 CPU, 3 GHz, 8GB RAM	5
Desktop PC Core i5, 3 GHz, 8GB RAM	7
Desktop PC Core i5, 2.4 GHz	8
Laptop	8
Plotter 24 inch	1
Laser Printer	3
Photo copier Machine	1
Scanner	4
Digital Single-lens Reflex Camera	3
Spiral Machine	2
Internet connection (High speed 512 kbps Uplink and Down Link)	3
Online IPS, 3000 VA	1
Online UPS	7
Standby Generator	1

- A library enriched with theoretical & practical technical Literature

LIST OF EQUIPMENT & MATERIALS

Sl.	Name of Items		Quantity
1.	Concrete Mixture Machine (10 cft. & 12 cft.)		2 Nos.
2.	Concrete Vibrator (25 mm dia & 38mm dia)		4 Nos.
3.	Water Pumps 1 H.P.& 1.5 H. P (220 V)		4 Nos.
4.	Diesel Generator 10 K.W.		3 Nos.
5.	Pilling Rig		2 Nos.
6.	Hydraulic Punch Machine		2 Nos.
7.	Earthling test Meter (Digital)		1 Nos.
8.	Electric Drill Machine (3 mm to 38 mm)		2 Nos.
9.	Hammers (1lb. to 6 lbs.)		2 Sets.
10.	Slides Wrench (6/8/10/12/36 inches)		6 Sets.
11.	Hack Saw with Frame		6 Sets.
13.	Tools for Installation of Equipment's:		
	Tie Cutter, Heat Gun, Pulley, Energy Meter, Total, Gutty set, Monkey Player, Ale key set, Repeat Gun, Hand punch, Vacuum Cleaner etc.		2 Sets.
14.	PH Meter	Range: 0.0 – 14.0 PH Hanna Instruments	1
15.	Pocket Conductivity Tester	TDScan3 Range: 0- 1990 µS	1
16.	TDS Meter		1
17.	Pocket Wind Meter	Range: 0.3 – 40 M/S, Kestrel 1000	1
18.	Sound Level Meter	Range: 32 – 130 dB Blue Gizmo (BG 325)	1
19.	Iron Testing Kit	Range: 0 – 5 mg/l HACH (IR – 18)	1
20.	Arsenic Testing Kit	Range: 0 – 1 mg/l ITS (Econo – Quick)	1
21.	Bacteria Testing Kit	Present/Absent ITS	1
22.	Chemical Balance	Cap.: 1mg – 100 gm	1

23.	Weighing Scale	Cap.: 2 Kg (5 lb)	1
		MISAKI (Japan)	
24.	Platform Weighing Scale	Cap:500 Kg	1

25.	Hand Tachometer	Model:26947	1
		Cap:100 – 10000 R.P.M.	
26.	AVO Meter	Digital	6
27.	Clip-on Meter (Multi-meter)	Digital	3
28.	Insulation Tester (Megger)	Model: 1010T	1
		1600V,0-1000 M ohms	
29.	Earthing Tester	Model:3150 (HIOKI)	1
30.	Cable Punching M/c		1
31.	Soldering Iron		1
32.	Lathe Machine, 5'-0" long	36" B.L. x 20" swing	1
33.	Lathe Machine 6'-0"	48" B.L. x 24" swing	1
34.	Lathe Machine 6'-6"	54" B.L. x 24" swing	1
35.	Lathe Machine 10'-0"	96" B.L. x 28" swing	1
36.	Roller Machine	1500Lx1500Wx1200H	1
37.	Hydraulic Press Machine	Capacity-300 tons	1
38.	Radial Drill Machine	1500Lx900Wx2400H	1
39.	Shaping Machine	2480Lx1400Wx1780H	1
40.	Grinder Machine	470Lx300Wx440H	1
41.	Milling Machine	770Lx880Wx1160H	1
42.	Hydraulic Share Machine	Capacity 300 tons	1
43.	Overhead Monkey Crane	Capacity-20 tons	2
44.	Shaping Machine	Stroke – 30"	1
45.	Pedestal Drilling Machine	Cap. 1.1/2" dia x 5" depth	1
46.	Pedestal Grinding M/c	Double Ended, 8" dia	1
47.	Pedestal Polishing M/c	2"-12" dia	1
48.	Sheet Cutting Machine	Cap. 14 swg	1
49.	Sheet Bending Machine	Cap. 14 swg	1

50.	Pipe Bending Machine	10/13 mm	2
51.	Hand Drilling Machine	Cap. 1/2" dia	7
52.	Hand Grinding Machine	Size: 4" dia	9
53.	Hand Grinding Machine	Size: 7" dia	1
54.	Pipe Cutter	Cap.: 1.1/2" dia	1
55.	Electric Welding Machine		7

56.	MIG Welding Machine	Murex 285, 40-300 A	1
57.	Argon Welding Machine		2
58.	Gas Cutting Set		1
59.	Vernier Caliper	6" size	3
60.	Vernier Caliper	8" size	1
61.	Depth Gauge	6" size	1
62.	Measuring Tape, Steel	3m long	10
63.	Measuring Tape, Cotton	50' – 0" long	1
64.	Measuring Pot, S. S.	1 lit	1
65.	Spirit Level	12" long	2
66.	Spirit Level	48" long	1
67.	Air Blower		1
68.	Air Compressor		1
69.	Painting Gun		1
70.	Rivet Gun	Cap.: 1/8" dia	1
71.	Master Pressure Gauge	3" dia x 0 – 300 mbar	3

Special Tools & Tackles for STEAM TURBINE GENERATOR SET:

Sl. No.	Description	Unit	Quantity
01	Standard Resistance Box	Pcs	01
02	High Voltage DC Generator 120KV/2mA	Pcs	01
03	Microcomputer Based Relay Protection testing Device	Pcs	01
04	Wheatstone Bridge	Pcs	01
05	Double Bridge	Pcs	01

06	Current Transformer 600/5A	Pcs	01
07	Current Transformer 50/5A	Pcs	01
08	Portable Lamp Transformer 1KVA 240V to 36V	Pcs	01
09	Sequence Table (Electronic)	Pcs	01
10	Earth Resistance Tester	Pcs	01
11	AC Ammeter	Pcs	01
12	AC Voltmeter	Pcs	01
13	DC Millivoltmeter	Pcs	01
14	DC Milliammeter	Pcs	01
15	DC Resistance Tester	Pcs	01
16	Pincers Phase Meter	Pcs	01
17	Clamp Type Electric Current meter	Pcs	01
18	Electrical Signal tester	Pcs	01
19	Standard Voltmeter 0.5 Level	Pcs	01
20	Standard Ampere meter 0.5 Level	Pcs	01
21	AC-DC Test Transformer	Pcs	01
22	Manual Operation Type Transformer Box	Pcs	01
23	Single Phase Voltage Regulator 2KVA	Pcs	01
24	Tri Phase Voltage Regulator 3KVA	Pcs	01
25	Megger (Digital) 1000V	Pcs	01
26	Megger (Digital) 500V	Pcs	02
27	Megger (Mechanical) 2500V	Pcs	01
28	Universal Instrument (digital)	Pcs	02
29	Universal Instrument (Mechanical)	Pcs	01
30	Cable reel 1.5mm ² , L=30m	Pcs	01
31	Triangular Scrapper 300mm	Pcs	01
32	Steel Shop	Pcs	01
33	Single Head Wrench 32, 36,41mm	Pcs	03
34	Vernier Caliper 0-300mm	Pcs	01
35	Depth Gage 0-300mm	Pcs	01
36	Magnetic water Levels	Pcs	01
37	Outside Micrometer 0-25mm	Pcs	01
38	Dial gage Small indication 0-10mm	Pcs	03
39	Dial gage Small indication 0-03mm	Pcs	01
40	Magnetic stand	Pcs	03
41	Frame Level Meter L=150mm	Pcs	02
42	Torque Wrench	Pcs	02

At A Glance of Major Clients

EPC/Turnkey Projects & Thermal Projects:

Sl. No.	Customers/Projects	Location	Products/jobs/services	Status
1	Square Hospitals Ltd. (State of the art hospitals owned by Square Group)	18F, West Panthapath, Dhaka	Waste Heat Recovery Hot water system includes supply, installation & commissioning of HRS, calorifier & electric boiler of Astras System	Installed & commissioned
			Water treatment system includes pre-treatment & post treatment (RO) system	In operation
			Plumbing system for hospitals & biomedical unit	Running
			Steam & condensate system of laundry including supply & installation of steam boiler	Running
2	RPCL 50MW HFO Power Plant (An IPP EPC contracted by: CPCL and constructed by Wartsila Engines)	Kodda, Gazipur	Mechanical Turnkey Erection & Fabrication Jobs includes detail designing of piping, ducting, overhead trance & structure system	Installed & commissioned
			Levelling & alignment of 6 nos Wartsila Engines 86 ton each and all engine and fuel treatment house auxiliaries	Running
			All Piping System includes HFO, LFO, Steam & condensate, Compressed Air, Lube oil, cooling water includes radiators installation, Raw & DM Water, oily water, sludge water etc	Installed & commissioned
			Exhaust System includes ducts, supports, silencer & stack structure	Running
			Charge Air & 77 ventilation system	Installed & commissioned
3	IL Bangla Ltd. (A Textile company owned by Interloop, Pakistan)	Pachdona, Narsingdi	Designing, supply, fabrication & erection of all piping (Steam, condensate, compressed air, raw water, DM water, chilled water, chemical) & ducting system	Installation is going on
			Designing, supply, fabrication & erection of tanks, staircases, railing & gates etc.	Installation is going on
4	Baraka Patenga Power Ltd. 50MW HFO Independent Power Plant on Rolls-Royce Engine. Owned by Barakatullah Electroynamics Ltd	Patenga, Chittagong	Dual pressure superheated heat recovery boiler with steam turbine for secondary power generation	Running

			Auxiliary or start-up firing system	Running
			Water treatment system & cooling water system	Running
5	Towa Personal Protective Device BD Ltd. (A Japanese Textile Company)	IEPZ, Iswardi, Pabna	Supply, installation & commissioning of Dual (Gas + Diesel) Steam Boiler	Installed
			Supply, installation & commissioning of waste water treatment system	Installed
			Designing, supply, fabrication & erection of all piping & ducting system	Installed
6	Rajshahi Auto Bricks Ltd. (An energy efficient and environment friendly brick making industry)	Nowhata, Rajshahi	Engineering, Procurement & construction of the whole plant. This includes bank processing, civil, mechanical and electrical works plus 6 month running contracts	Running
7	United Ashugonj Energy Limited	Ashugonj, B. Baria	River cooling water system and water treatment system for 16MW cogeneration project of 200MW United Ashugonj Energy Limited	Installed
8	N B Filling Station	Kechuatail, Rajshahi	Engineering, Procurement & construction of the whole plant. This includes bank processing, civil, mechanical and electrical works.	On going

Boiler:

Sl.	Customer	Location	Product	Capacity	Brand/Origin	Status
1	Square Hospitals Ltd.	18F, West Panthpath, Dhaka	Waste Heat Recovery Hot Water Boiler with calorifiers	32 m3/hr, 90degC	ME Energy, India	Running
2	Square Hospitals Ltd.	18F, West Panthpath, Dhaka	Electric Hot Water Boiler	32 m3/hr, 90degC	ME Energy, India	Running
3	Square Laundry	Tegaon I/A, Dhaka-1208	Dual (Gas+Diesel) Steam Boiler	1 ton/hr, 10 bar	Aktes, Turkey	Running
4	Baraka Patenga Power Ltd.	Patenga, Chittagong	Dual pressure superheated heat recovery boiler with steam turbine for secondary power generation	2.6 ton/hr, 16 bar, 288 degC	Greens, Singapore	Running
5	Baraka Patenga Power Ltd.	Patenga, Chittagong	Diesel fired steam boiler for start-up	5 ton/hr, 10 bar, saturated	Greens, Singapore	Running

6	Towa Personal Protective Device BD Ltd. (A Japanese Company)	IEPZ, Iswardi, Pabna	Dual (Gas + Diesel) Steam Boiler	2x2 Ton/hr	Aktes, Turkey	Installed
---	--	----------------------	----------------------------------	------------	---------------	-----------

Engineering Fabrication:

Sl. No.	Customer	Location	Product	Specification	Quantity	Status
1	Neo Zipper Company Ltd.	Kathaldia, Tongi, Gazipur	Pressure Vessel	1000 litre, MOC: MS	1 Set	Running
2	A.K. Washing & Dyeing Ltd	Board Bazar, Gazipur	Pressure Vessel	1500 litre, MOC: MS	1 Set	Running
3	Ultra-Washing & Dyeing Ltd.	BaroDewra, Charagali, Tongi	Chemical Mixing Tank	300 litre, MOC: AISI 304	2 Sets	Running
4	Mark Fabrics (Washing) Ltd.	BSCIC, Tongi	Water Storage Tank	2000 litre, MOC: MS	1 Set	Running
5	Navana CNG Ltd.	Tejgaon I/A, Dhaka	Gas Leak Detector	Alarm type, Korea	10 Sets	Running
6	PHP Ship Breaking Ind. Ltd.	Sitakundong, Chittagong	Room Structure	I Beam, U Channel	1 Lot	Running
7	Rahimafrooz Batteries Ltd.	Zirani Bazar, Savar, Dhaka	Pressure Vessel	1000 litre, MOC: MS	1 Set	Running
8	AdarshoTubewell Agency	28/A, Hazi Osman Goni Road,	Tube Pack Media	PVC	1 Lot	Running
9	Prime Drinking Water	Uttarkatia, Satkhira	Water Storage Tank	2000 litre, MOC: AISI 304	1 No	Running
10	Five Star Engineering Works	3705/B2, North Sharaipara, Chittagong.	Oil Storage Tank	5000 litre, MOC: MS	1 Set	Running
11	Cotton Club (BD) Ltd.	Kashimpur Road, Gazipur	Pressure Vessel	2000 litre, MOC: MS	2 Sets	Running
12	Techno-drive Engineering & Consultancy	Mohakhali DOHS, Dhaka	Gas Leak Detector	Alarm type, Korea	15 Sets	Running

13	SME Trade Corporation	Atomic Energy Comm., Savar	DM Water Storage Tank	3500 litre, MOC: AISI 304	1 No	Running
14	Partex Beverage Ltd.	74, BirUttam A.K. Khandaker Sarak,	Chemical Mixing Tank	1000 litre, MOC: AISI 316	1 Set	Running
		Mohakhali C/A, Dhaka-1212.	Chemical Mixing Tank	4000 litre, MOC: AISI 316	3 Sets	Running
15	Tex Zippers (BD) Ltd.	Adamjee EPZ, Adamjee Nagar	Boiler Chimney	12" dia x 32'H, MOC: MS	1 Set	Running
16	Sparrow Apparels Ltd.	Plot # 251, Chandara, Laxmipur, Gazipur	Boiler Chimney	24" dia x 36'H, MOC: MS	1 Set	Running
17	IL Bangla Ltd	Pachdona, Norshingdi	SS Tank, Stair, Air Duct		1 Lot	Running
18	Square Hospitals Ltd	West Panthopath, Dhaka	SS Tank,		2 Sets	Running

Industrial Erection Works:

Sl. No.	Customer	Location	Product	Description	Status
1	Potato Flakes (BD) Ltd.	Nair Pukurpar, Munshigonj Shadar, Munshigonj	Food Machinery	m/c inst., ss piping works	Completed
2	Rising Balaka Washing & Dyeing Ind. Ltd.	22/1, Millgate, Monno Nagar, Tongi I/A, Gazipur	Washing Machinery	m/c inst., MS/GI piping works	Completed
3	Ultra-Washing & Dyeing Ltd.	BaroDewra, Charagali, Tongi	Washing Machinery	m/c inst., MS/GI piping works	Completed
4	Mark Fabrics (Washing) Ltd.	BSCIC, Tongi	Washing Machinery	m/c inst., MS/GI piping works	Completed
5	HRG Engineering	112/2/Ka, 1 st Floor, East Rampura Dhaka-1219	Cooling Tower Inst.	CT supply, inst. & piping works	Completed

6	Givensee Food & Essentials Ltd. (Givensee Group of Ind. Ltd.)	H-06, R-13, Sector-03, Uttara Model Town, Uttara, Dhaka	Food Machinery installation	m/c inst., ss piping works	Completed
7	Jeans Washing Ind. Ltd.	52, Abdul Gofur Khan Road, Shilmon, Tongi, Gazipur-1710	Washing Machinery installation	m/c inst., MS/GI piping works	Completed
8	Square Pharmaceuticals Ltd.	48, Mohakhali C/A, Dhaka	Elec. Instruments	supply & installation	Completed
9	Cemex Cement (BD) Ltd.	76(57/40), K.N. Sen Road, Mahmud Nagar Bandar, Narayanganj	WTP Automation	Timer based instruments & automation	Completed
10	Five Star Engineering Works	3705/B2, North Sharaipara, Chittagong.	Oil Factory Installation	m/c & tank inst., piping	Completed
11	BOC Bangladesh Ltd.	285, Tejgaon I/A, Dhaka-1208	WTP Civil Tank	RCC works	Completed
12	Tex Zippers (BD) Ltd.	Plot#180, Adamjee EPZ, Adamjee Nagar Shiddirgonj, Narayanganj	Machinery installation	m/c inst., MS/GI piping works	Completed
13	United Ashugonj Energy Ltd.	Ashugonj, B. Baria	Steam Turbine Generator	Mechanical & Electrical Erection work for 16MW STG	Completed
14	Akij Particle Board Ltd	Trishal, Mymensingh	Machines Installation	Fabrication & installation of Ducting, foundation, support structures	Completed

ETP/STP:

SL NO	Customer Name	Location	Product	Capacity	Status
1	Neo Zipper Company Ltd.	Kathaldia, Tongi, Gazipur	ETP-5CMH	5 m3/hr	Running
2	Perfect Washing Plant	Board Bazar, Gazipur	ETP-10CMH	10 m3/hr	Running
3	Rising Balaka Washing & Dyeing Inds. Ltd	Monno Nagar, Tongi	ETP-50CMH	50 m3/hr	Running
4	A.K. Washing & Dyeing Ltd	Board Bazar, Gazipur	ETP-25CMH	25 m3/hr	Running

5	Ultra-Washing & Dyeing Ltd.	BaroDewra, Squib Road, Charagali, Tongi	ETP-20CMH	20 m3/hr	Running
6	Design Washing	Shilmon, Tongi	ETP-25CMH	25 m3/hr	Running
7	Confidence Washing	Mirpur-11, Dhaka	ETP-15CMH	15 m3/hr	Running
8	Mark Fabrics (Washing) Ltd.	BSCIC, Tongi	ETP-15CMH	15 m3/hr	Running
9	Square Pharmaceuticals Ltd	Pabna Unit	ETP machinery	2 m3/hr	Running
10	Pearl Washing	Abdul Gafur Road, Tongi,	ETP-35CMH	35 m3/hr	Running
11	Sunman Textiles Ltd.	Kadamrasul, Sitakundo, Chittagong	ETP-50CMH	50 m3/hr	Running
12	Cotton Club (BD) Ltd.	South Jarun, Kashimpur, Konabari, Gazipur	ETP-40CMH	40 m3/hr	Running
13	Mega Yarn Dyeing Mills Ltd	H#3/B (2 nd Floor), Uttara	ETP-100CMH	100 m3/hr	Running
14	Jeans Washing Ind. Ltd.	Abdul Gafur Khan Road, Shilmon, Tongi,	ETP-35CMH	35 m3/hr	Running
15	Print Asia Ltd.	PurbaDogori, Mirzapur, Gazipur	ETP-2CMH	2 m3/hr	Running
16	Admiral Denim Washing Ltd.	Abdul Gafur Khan Road, Shilmon, Tongi,	ETP-25CMH	25 m3/hr	Running
17	Shovon Washing Plant Ltd.	Zirani Bazar, Savar, Gazipur	ETP-35CMH	35 m3/hr	Running
18	Indigo World Design	Abdul Gafur Khan Road, Shilmon, Tongi,	ETP-15CMH	15 m3/hr	Running
19	Tex Zippers (BD) Ltd.	Adamjee EPZ, Narayangonj	ETP-5CMH	5 m3/hr	Running
20	V-Knitwear & Composite Ltd.	Rupgonj, Narayangonj	ETP-50CMH	50 m3/hr	Running
21	Premier Indo-Aluminium Co.	Srepur, Gazipur	ETP-20CMH	20 m3/hr	Running
22	Meghna Knit Composite Ltd.	Gilarchala, Srepur, Gazipur	ETP-80CMH	80 m3/hr	Running

23	Cemex Cement BD Ltd.	Mahmud Nagar, Bandar, Narayanganj	STP-30CMD	2 m3/hr	Running
24	Meghna Knit Composite Ltd.	Gilarchala, Srepur, Gazipur	ETP-Civil works	80 m3/hr	Running
25	Dhaka Thai Ltd.	Srepur, Gazipur	ETP-20CMH	20 m3/hr	Running
26	Kallol Thai President Foods (BD) Ltd.	Tetirbari, Telihati, Sreepur, Gazipur	ETP-2CMH	2 m3/hr	Running
27	M.L. Dyeing Ltd.	Zamirdia, Bhaluka, Mymensingh	ETP-50CMH	50 m3/hr	Running
28	National Composite Knit Ltd.	B-18 (Part), BSCIC I/A, Tongi, Gazipur	ETP-15CMH	15 m3/hr	Running
29	Prominent Lube Ltd.	BSCIC I/A, Hobigonj	ETP-3 CMH	3 m3/hr	Running
30	Towa Protective Device (BD) Ltd	IEPZ, Pakshey, Pabna	ETP-15CMH	15 m3/hr	Under Construction
31	Aquatech Washing and Dyeing Ltd.	Shilmon , Tongi, Gazipur	ETP-25CMH	25 m3/hr	Running
32	Prominent Lube Ltd	BSCIC I/A, Hobigonj	ETP-3CMD	3m3/day	Running
33	Apparels Art Washing Ltd.	Mogor Khal, Gazipur	ETP-50 CMH	50 m3/hr	Under construction
34	Leon Pharmaceuticals Ltd.	Satkhamair, Sreepur, Gazipur	ETP-1 CMH	1m3/hr	Running
35	ACI Health Care Ltd.	Sonargaon, Narayanganj	ETP-10 CMHH	10 m3/hr	Under construction
36	MNS Yarn Dyeing Ltd.	Mogor Khal, Gazipur	ETP-10 CMHH	10 m3/hr	Under construction
37	Cemex Cement BD Ltd.	Mahmud Nagar, Bandar, Narayanganj	STP-30CMD	2 m3/hr	Running
38	Kallol Thai President Foods (BD) Ltd.	Tetirbari, Telihati, Sreepur, Gazipur	STP-1CMH-Design	1 m3/hr	Running
39	Aysha Memorial Hospital	Mohakhali, Dhaka	STP - 1.5CMH-Design	1.5 m3/hr	Running
40	Prominent Lube Ltd	BSCIC I/A, Hobigonj	STP - 3CMD	3 m3/day	Running
41	Saiham Properties (Saiham Tower)	Gulshan-1, Dhaka	STP - 50 CMD	50 m3/day	Running
42	ACI Health Care Ltd.	Kanchpur, Narayanganj	STP - 60 CMD	3 m3/hr	Running
43	BTI Landmark Tower	Gulshan-2, Dhaka	STP - 5000 GPD	1.5 m3/hr	Running

44	Golden Harvest Foods Ltd.	186, Tejgaon I/A, Dhaka - 1208	ETP-50000 LPD	3 m3/hr	Running
----	---------------------------	--------------------------------	---------------	---------	---------

WTP:

Sl. No.	Customer	Location	Product	Capacity	M.O.C	Status
1	Potato Flakes (BD) Ltd.	Nair Pukurpar, Munshigonj	IF	30 m3/hr	S.S 304	Running
2	Neo Zipper Company Ltd.	Kathaldia, Tongi, Gazipur	MMF	5 m3/hr	M.S	Running
3	Perfect Washing Plant	Board Bazar, Gazipur	MMF	10 m3/hr	M.S	Running
4	Rising Balaka Washing & Dyeing Inds. Ltd	Monno Nagar, Tongi	WS, MMF	50 m3/hr	M.S	Running
5	A.K. Washing & Dyeing Ltd	Board Bazar, Gazipur	MMF	25 m3/hr	M.S	Running
6	Maksons Spinning Mills Ltd.	Goripur, Asulia, Dhaka	WS	10 m3/hr	M.S	Running
7	Nowapara Jute Mills	Nowapara, Jessore	WS, MMF	1.2 m3/hr	FRP	Running
8	Confidence Washing	Mirpur-11, Dhaka	MMF	15 m3/hr	M.S	Running
9	Ultra-Washing & Dyeing Ltd.	BaroDewra, Charagali, Tongi	MMF	20 m3/hr	M.S	Running
10	Ultra-Washing & Dyeing Ltd.	BaroDewra, Charagali, Tongi	WS	3 m3/hr	FRP	Running
11	Ultra-Washing & Dyeing Ltd.	BaroDewra, Charagali, Tongi	SF, WS	60 m3/hr	M.S	Running
12	Design Washing	Shilmon, Tongi	MMF	15 m3/hr	M.S	Running
13	Mark Fabrics (Washing) Ltd.	BSCIC, Tongi	MMF	15 m3/hr	M.S	Running
14	Poly Cables Ind. Ltd.	Daudkandi	IF, CF, WS	5 m3/hr	FRP	Running
15	BOC BD Ltd.	Sitakundo, Chittagong	WS	17 m3/hr	M.S	Running
16	Ruhul Amin CNG Station	Sonainuri bus stand, Noakhali	WS	5 m3/hr	FRP	Running
17	Navana CNG Filling Station	Tangail Bus Stand, Tangail	SF, IF, WS	1 m3/hr	FRP	Running
18	Square Pharmaceuticals Ltd.	Pabna unit	WS	10 m3/hr	M.S	Running
19	PHP Ship Breaking Ind. Ltd.	Sitakundo, Chittagong	A, IF, CF	1 m3/hr	S.S 316	Running
20	Rahimafrooz Accumulators Ltd.	Zirani Bazar, Savar, Dhaka	SF, IF, WS	500 lit/hr	FRP	Running

21	Cotton Club (BD) Ltd.	Kashimpur Road, Gazipur	MMF, CF, WS	60 m3/hr	M.S	Running
22	Rahimafrooz Batteries Ltd.	Zirani Bazar, Savar, Dhaka	SF, IF, WS	1 m3/hr	FRP	Running
23	Rahimafrooz Batteries Ltd.	Zirani Bazar, Savar, Dhaka	SF, IF	1 m3/hr	FRP	Running
24	Sathgao Tea Estate	Moulobibazar, Sylhet	SF, IF, WS	1 m3/hr	FRP	Running
25	Hotapara Garments Ltd.	Monipur, Hotapara, Gazipur	SF, WS	12 m3/hr	FRP	Running
26	Givensee Foods & Essentials Ltd.	Monipur, Hotapara, Gazipur	WS	500 lit/hr	FRP	Running
27	Givensee Foods & Essentials Ltd.	Monipur, Hotapara, Gazipur	MMF, CF, WS, MF, UV	3 m3/hr	FRP+S S 304	Running
28	Safaa Sweaters Ltd.	Asulia, Savar, Dhaka	WS	1 m3/hr	FRP	Running
29	SIAM CNG Station	Mawna Chowra sta, Gazipur	IF, WS	1 m3/hr	FRP	Running
30	Dewan CNG Station	Chandana, Sripur, Gazipur	IF, WS	1 m3/hr	FRP	Running
31	SME Trade Corporation	Atomic Energy Comm., Savar	C, MF, MB	500 lit/hr	SS 304	Running
32	Energis Power Corp. Ltd.	Silalbaha, Chittagong	SF, IF	15 m3/hr	MS	Running
33	Navana CNG Ltd.	Tejgaon I/A, Dhaka	IF, WS	1 m3/hr	FRP	Running
34	CEMEX Cement (BD) Ltd.	Bandar, Narayanganj	SF, IF, WS	5 m3/hr	MS	Running
35	SME Trade Corporation	Atomic Energy Comm., Savar	MF, RO, DI	200 lit/day		Running
36	BOC Bangladesh Ltd.	Tejgaon I/A, Dhaka	MMF, WS	25 m3/hr	MS	Running
37	Padma Poly Cotton Knit Fabrics Ltd.	Tejgaon I/A, Dhaka	MMF, CF, WS (2)	200 m3/hr	MS	Running
38	RZ Power Ltd.	Thakurgao	RO	250 lit/hr	Imp.	Running
39	Navana CNG Ltd.	Tejgaon I/A, Dhaka	UV, D	40 lit/hr	SS	Running
40	Asian Specialised Textile Mills Ltd.	West Mukterpur, Munshigonj	SF, IF, WS	45 m3/hr	MS	Running
41	Indigenous Engineers Ltd.	Nikunja North, Dhaka	WS	3 m3/hr	FRP	Running
42	Sparkle Knit Composite Ltd.	Kabirpur, Savar, Dhaka	OC, SF, WS	100 m3/hr	MS	Running
43	Reedisha Knitex Ltd.	Dhanua, Nayanpur, Sreepur, Gazipur	WS (2)	12 m3/hr	FRP	Running
44	ACI Salt Ind. Ltd.	Rupgonj, Narayanganj	SF, WS	25 m3/hr	MS	Running

45	RAK Paints Pvt. Ltd.	Hobigonj	MMF, WS, RO, UV	6 m3/hr	FRP	Running
46	GBB Power Ltd.	Puran Road, Bogra	SF, IF, RO, DI	40 lit/hr	FRP	Running
47	Indigenous Engineers Ltd.	Mohadevpur, Naogaon	SF, IF, WS	5 m3/hr	FRP	Running
48	Shahrier Steel Mills Ltd.	Demra, Dhaka	WS	1 m3/hr	FRP	Running
49	RZ Power Ltd.	Thakurgao	IF	250 lit/hr	FRP	Running
50	AKW Group	Banani, Dhaka	RO	14 lit/hr	Imp.	Running
51	Agronest Pvt. Ltd.	BSCIC, Jinaidah	RO+MB	500 lit/day	Imp. +SS304	Running
52	M/S Surma Automatic Rice Mills	Hobigonj	SF, IF, WS	5 m3/hr	FRP	Running
53	RAK Paints Pvt. Ltd.	Hobigonj	RO, UV	1 m3/hr	Imp.	Running
54	J.M. Water Company	Shalgaria, Pabna	RO, UV	40 lit/hr	Imp.	Running
55	RAK Paints Pvt. Ltd.	Hobigonj	UV	3 m3/hr	FRP	Running
56	Crown Wears Sweaters Ltd.	Zamirdia, Bhaluka, Mymensingh	MMF, CF	6 m3/hr	FRP	Running
57	Zen Power International	Mohadevpur, Naogaon	SF, WS	6 m3/hr	FRP	Running
58	Grameen Fabrics & Fashions Ltd.	Mirpur-2, Dhaka	RO, UV	1 m3/hr	Imp.	Running
59	Square Hospitals Ltd.	West Panthopath, Dhaka	OC, MMF, CF, WS	16 m3/hr	SS 304	Running
60	NIPRO JMI Company Ltd.	Gozaria, Munshigonj	SF, IF, CF, WS, RO, CE, AE, UV	20 m3/hr	MS+FR P+SS304	Running
61	Kallol Thai President Foods (BD) Ltd.	Sreepur, Gazipur	SF, CF (2), WS	5 m3/hr	FRP	Running
62	Baraka Patenga Power Ltd.	Patenga, Chittagong	MMF (2), IF, CF, MF, RO (2), MB	8 m3/hr	MS+FR P+Imp.	Running
63	Navana Pharmaceuticals Ltd.	Rupshi, Rupgonj, Narayanganj	IF	500 lit/hr	FRP	Running
64	Agronest Pvt. Ltd.	BSCIC, Jinaidah	UV	40 lit/hr	Imp. +SS304	Running
65	Time Power Engineering Ltd.	Savar, Dhaka	SF, IF, WS	1 m3/hr	FRP	Running
66	CEMEX Cement (BD) Ltd.	Bandar, Narayanganj	SF, IF, WS	15 m3/hr	MS+Auto	Running
67	Hatim Industries Ltd.	279, Morkun, Tongi, Gazipur	WS	1 m3/hr	FRP	Running
68	LA CASITA Apartment Owners Asso	Dhanmondi, Dhaka	SF, IF, CF	7 m3/hr	FRP	Running

69	Envoy Textiles Ltd.	Jamirdia, Valuka, Mymensingh	OC, MMF, WS	120 m3/hr	MS	Running
70	IL Bangla Ltd.	Pachdona, Norshingdi	SF, IF	50 m3/hr	MS	Running
71	Reedisha Knitex Ltd.	Dhanua, Nayanpur, Sreepur, Gazipur	WS	12 m3/hr	FRP	Running
72	Power Flame Ltd.	Naogaon	MMF	5 m3/hr	FRP	Running
73	Square Hospitals Ltd.	West Panthopath, Dhaka	MMF, CF, WS (2), RO, UV	1 m3/hr	MS+FR P+Imp.	Running
74	Energypac Power generation Ltd.	108 MW IPP, Potia, Chittagong	FFM, LC, IF, MMF, WS, RO	13.5 m3/hr	MS+FR P+Imp.	Running
75	Digital Power & Associates Ltd.	Gognagar, Kashipur, Narayanganj	MMF, CF, WS, RO	4 m3/hr	FRP+I mp.	Running
76	Square Pharmaceuticals Ltd.	48, Mohakhali C/A, Dhaka	SF, IF, CF, RO, UV	500 lit/hr	FRP+I mp.	Running
77	ZK Foils Ltd.	Shimrail, Siddirganj, Narayanganj	WS	5 m3/hr	FRP	Running
78	Incepta Pharmaceuticals Ltd.	Bara Rangamatia, Zirabo,Savar, Dhaka	WS	4 m3/hr	FRP	Running
79	ACI Food Ltd.	Shirajgonj,	WTP	15m3/hr	FRP	Installed
80	Beximco Pharmaceuticals Ltd.	Cherag Ali, Tongi	WTP	5m3/hr	FRP	Installed
81	United Engineering & Power Services Ltd.	CEPZ, Chittagong	Pre- treatment	15m3/hr	FRP	Installed
82	United Ashugonj Energy Ltd.	Ashugonj, B. Baria	WTS, DM (RO+EDI)	2x4m3/hr	FRP	Running
83	Dhaka Southern Power Ltd	Nababganj, Dhaka	WTS, DM (RO+EDI)	5 m3/hr	FRP	Running
84	Dhaka Northern Power Ltd	Manikganj, Dhaka	WTS, DM (RO+EDI)	5 m3/hr	FRP	Running
85	Zam Zam Drinking Water	Umednagar, Habigonj	SF, IF, CF, MF, UV	1 m3/hr	FRP	Running
86	Towa Personal Protective Device (BD) Ltd	IEPZ, Ishurdi,Pabna	MMF, WS	1 m3/hr	FRP	Running
87	Genesis Fashion Ltd	Kadda, Gazipur	MMF, ACF	1500 Litre/hr	FRP+I mp	Running
88	Square Hospitals Ltd.	West Panthopath, Dhaka	OC, MMF, CF, WS (2 Sets)	20 m3/hr	SS 304	Running
89	Columbia Washing Plant Ltd., Unit – 1	Hotapara, Gazipur	SF, WS	170 m3/hr	MS	Running
90	Columbia Washing Plant Ltd., Unit – 1	Gazipur	MMF, ACF, MF, UV	5 m3/hr	FRP	Running
91	Charuta Private Ltd	Gulshan-2, Dhaka	MMF, ACF	500 litre/hr	FRP	Running

92	Rahim Steel Mills Ltd	Narayangonj	SF, IF, CF, MF, UV	3m3/hr	FRP	Running
93	Shaiham Properties Ltd	Gulshan-2, Dhaka	MMF, IF, CF	35m3/hr	FRP+I mp.	Running
94	Shaiham Properties Ltd	Gulshan-2, Dhaka	MMF, IF, CF	350 Litre/hr	FRP+I mp.	Running
95	Genesis Fashion Ltd	Kodda, Gazipur	WS	10m3/hr	FRP+I mp.	Running
96	Radiant Pharmaceuticals Ltd	BSCIC, Tongi	SF, WS	3 m3/hr	FRP+I mp.	Running
97	Dipon Infrastructure Services Ltd	100MW Jamalpur Power Plant	SF, IRF, WS, RO,	4m3/hr	FRP+I mp.	Running
98	Square Toiletries Ltd	Pabna	SF, IRF, WS, RO, EDI, UV	5 m3/hr	FRP+I mp.	Running
99	United Ashugated Ashugonj Energy Ltd.	Ashugonj, Brahmanbaria	OC, MMF, RO, EDI	10 / 4 m3/hr		Running
100	Reedisha Food and Beverage Ltd.	Dhanua, Nayanpur, Sreepur, Gazipur	SF, WS	12 m3/hr	FRP+I mp+MS	Running
101	Orion Pharma Ltd	Siddhirgonj, Narayangonj	MMF, IF, CF	40m3/hr	MS	Under construction
102	ACI Healthcare Ltd.	Sonargaon, Narayanganj	MMF, IF, CF	60m3/hr	FRP	Running
103	Asgar Ali Hospitals	Old Dhaka	MMF, IF, CF, RO	4 m3/hr	FRP	Installed
104	Opsonin Pharma	Barisal	MMF, WS	7 m3/hr	FRP	Running
105	Orion Pharma Ltd	Siddhirgonj, Narayangonj	MMF, IF, CF	40m3/hr	MS	Running
106	Opsonin Pharmaceuticals Ltd.	Barisal	MMF, WS	7 m3/hr	FRP+I mp.	Running
107	ACI Healthcare Ltd	Tripodi, Sonargaon, Narayangonj	MMF, IF, CF, WS	60 / 10 m3/hr	FRP+I mp.	Running
108	Square Hospitals Ltd.	West Panthopath, Dhaka	IF, CF	1 m3/hr	FRP+I mp.	Running
109	SF Textile Industries Ltd.	ML Tower, East Rampura, Dhaka	MMF, WS	250 lit/hr	FRP+I mp.	Running
110	Asgar Ali Hospital	Distillery Road, Gandaria, Dhaka	MMF, CF, WS, RO (2)	2 m3/hr	FRP+I mp.	Running
111	Khokon Charitable Foundation Hospital (M&J Group)	Sirajgonj	MMF, IF, CF, MF, UV	3 / 2 m3/hr	FRP+I mp.	Running
112	Montrims Ltd.	Mouchak, Kaliakoir, Gazipur	MMF, CF, WS (2)	50 m3/hr	MS	Running
113	Genesis Fashion Ltd	Kadda, Gazipur	WS	2 m3/hr	FRP	Running
114	Beximco Pharmaceuticals Ltd	Tongi, Gazipur	MMF (2), CF (2), WS (2)	73.5 / 27.5 m3/hr	FRP+I mp.	Under Construction
115	M A Hashem Residence, Sajeeb Group	Gulshan-1, Dhaka	SF, IF, CF, MF, UV	1 m3/hr	FRP+I mp.	Running

116	Charuta Private Ltd	KSA Embassy, Dhaka	SF, IF, CF, MF, UV	10 m3/hr	FRP+I mp.	Running
117	BEACON Pharmaceuticals Ltd.	Valuka, Mymensingh	CF	30 m3/hr	MS	Running
118	Energypac Power generation Ltd.	Sylhet Gas Field Ltd, Sylhet	SF, IF, CF, MF (2), UV, OZ	3 m3/hr	FRP+I mp.	Running
119	Square Pharmaceuticals Ltd. (Pabna)	Square Centre, Mohakhali, Dhaka	MMF, WS	500 Litre/hr	FRP+I mp.	Running
120	Square Pharmaceuticals Ltd. (Pabna)	Square Centre, Mohakhali, Dhaka	MMF, WS	500 Litre/hr	FRP+I mp.	Running
121	Square Pharmaceuticals Ltd. (Pabna)	Square Centre, Mohakhali, Dhaka	WS (2)	8m3/hr	FRP+I mp.	Running
122	United Mymensing Power Ltd.	Sharifpur, Jamalpur	OC, MMF, WS, RO, EDI	150 m3/hr, 2X 6 m3/hr	MS, FRP +Imp.	Running
123	Orion Power Rupsha Ltd	Rupsha, Khulna	MMF, IF, WS, RO, EDI	105m3/hr, 2x4.5 m3/hr	MS, FRP +Imp.	Running
124	Papertech Industries Ltd.	Rupgonj, Narayangonj	MMF, WS	5m3/hr	FRP+I mp.	Running
125	Northern Consumer Products Ltd. (M&J Group)	Sirajgonj	MMF, WS	8m3/hr	FRP+I mp.	Running
126	Energypac Power generation Ltd. (LPG Khulna)	Khulna	MMF, ACF, MF, RO, UV	500 LPH	FRP+I mp.	Running
127	Golden Harvest Foods Ltd	Sylhet	A, SF, IRF, ACF, WS,	10 m3/hr	FRP+I mp	Under Construction
128	Samin Textile Mills Ltd	Gazipur	MMF, WS	250 Litre/hr	FRP+Imp	Running
129	Confidence Power Rangpur Ltd	Rangpur	MMF, IF, WS, RO, EDI	70 m3/hr, 2 X 5 m3/hr	MS, FRP+I mp	Running
130	Dhaka Northern Power Generation Ltd	Manikgonj	OC, MMF, WS	25m3/hr	MS	Running
131	Dhaka Southern Power Generation Ltd	Nawabgonj	OC, MMF, WS	25m3/hr	MS	Running
132	Orion Power Sonargaon Ltd	Sonargaon, Narayangonj	MMF, IF, WS, RO, EDI	105m3/hr, 2x4.5 m3/hr	MS, FRP +Imp.	Running
133	Khokon Charitable Foundation Hospital (M&J Group)	Sirajgonj	AC, MMF, IRF, ACF, MF, UV	3 m3/hr	FRP+I mp	Running
134	Genesis Fashion Ltd	Kadda, Gazipur	MMF, ACF, MF, UV	2 m3/hr	FRP+I mp	Running
135	Jamia Islamia Madrasha	Mymensingh	MMF, IRF, ACF, MF, UV	3 m3/hr	FRP+I mp	Running
136	Jamuna Power Ltd	Jamuna Industrial Park, Hobigonj	LC, MMF, IF, WS	100 m3/hr	MS	Under Construction

137	Square Toiletries Ltd (Narayangonj)	Square Centre, Mohakhali, Dhaka	MMF, ACF, WS, RO, CE, AE, UV	250 LPH	FRP	Running
138	Square Food and Beverage Ltd. (Pabna)	Square Centre, Mohakhali, Dhaka	SF, ACF, RO, EDI	6.5 m ³ /hr, 1x3 m ³ /hr	FRP	Running
139	Confidence Power Rangpur Ltd.	Rangpur	MMF, ACF, WS, RO	80 m ³ /hr, 2 X 8 m ³ /hr	MS	Under Construction
140	Confidence Power Bagura Ltd.	Bagura	DMF, WS, RO, EDI	1x80 m ³ /hr, 2x8 m ³ /hr, 1x5 m ³ /hr	MS	Running
141	Confidence Power Bagura Unit-2 Ltd.	Bagura	DMF, WS, RO, EDI	1x80 m ³ /hr, 2x8 m ³ /hr, 1x5 m ³ /hr	MS	Running
142	Consort Flexipack Ltd.	BSCIC Industrial Estate, Kalurghat, Chattogram	MF, IF, WS	10 m ³ /hr	FRP	Under Construction

N.B: A = Aerator, C = Chiller, MMF = Multimedia Filter, SF = Sand Filter, IF = Iron Filter, CF = Carbon Filter, WS = Water Softener, MF = Micron Filter, MB = Mixed Bed, UV = Ultra Violet Water Processor, RO = Reverse Osmosis System, DI = Deionizer, D = Dispenser, FFM = Flash & Flocculation Mechanism, LC = Lamella Clarifier

CONTACT US



PIVOT ENGINEERING LTD.

389/B, MG Tower, DIT Road, Level-8, West Rampura, Dhaka-1219, Bangladesh.
Phone: +88-02-9343024, Cell: 01914-012318, 01715-297538 Fax: +88-02-9338076.

Email: info@pivotengg.com, pivotengg@gmail.com

www.pivotengg.com